

## FEATURES

- Direct Sensor Input
- High Output Torque
- Low Pointer Flutter
- High Input Impedance
- Over Voltage Protection
- Return to Zero

## DESCRIPTION

The CS8190 is specially designed for use with air-core meter movements. The IC provides all the functions necessary for an analog tachometer or speedometer. The CS8190 takes a speed sensor input and generates sine and cosine related output signals to differentially drive an air-core meter.

The output utilizes differential drivers which eliminated the need for a Zener reference and offers more torque. The device withstands 60V transients which decreases the protection circuitry required.

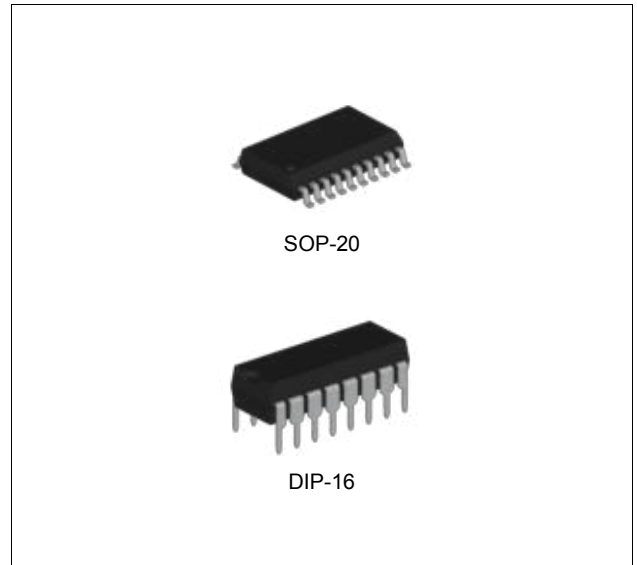

## ORDERING INFORMATION

Device	Package
CS8190D	SOP-20
CS8190N	DIP-16

## ABSOLUTE MAXIMUM RATINGS (Note 1)

CHARACTERISTIC	SYMBOL	MIN	MAX	UNIT
Maximum Supply Voltage (< 100ms Pulse Transient)	$V_{CC}$	-	60	V
Maximum Supply Voltage (Continuous)	$V_{CC}$	-	24	V
ESD Rating, HBM	-	4	-	kV
Operating Ambient Temperature	$T_A$	-40	105	°C
Junction Temperature	$T_J$	-40	150	°C
Storage Temperature	$T_{STG}$	-60	165	°C

Note 1. Stresses beyond those listed under *Absolute Maximum Ratings* may cause permanent damage to the device. These are stress ratings only and functional operation of the device at these or any other conditions beyond those indicated under *Recommended Operating Conditions* is not implied. Exposure to absolute-maximum-rated conditions for extended periods may affect device reliability.

**ORDERING INFORMATION**

Package	Order No.	Description	Supplied As	Status
SOP-20	CS8190D	Air-Core Tach/Speedo Driver	Tape & Reel	Active
DIP-16	CS8190N	Air-Core Tach/Speedo Driver	Tube	Contact us

**PIN CONFIGURATION**

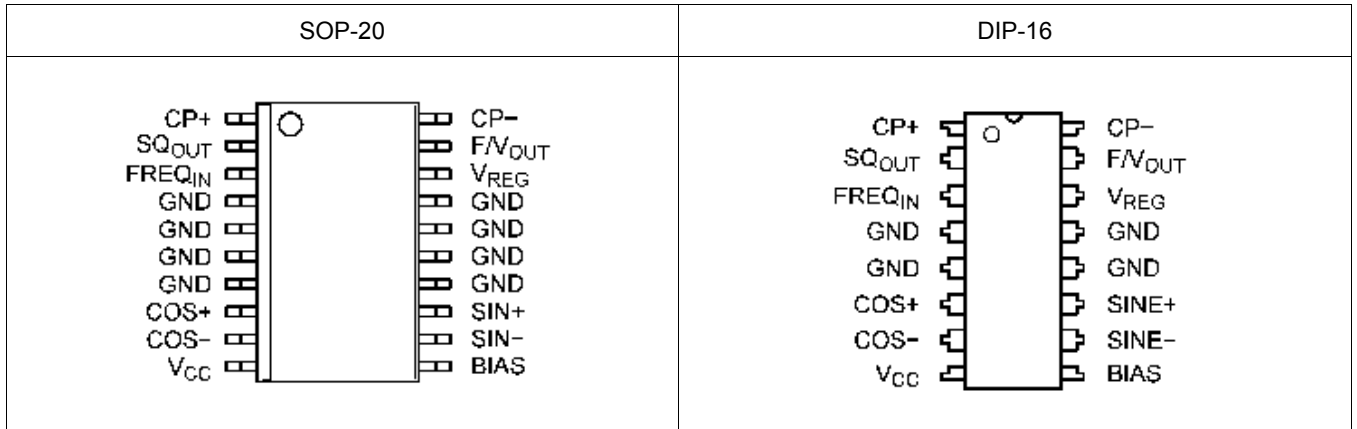

**PIN DESCRIPTION**

Pin No.		Pin Name	Pin Function
SOP-20	DIP-16		
1	1	CP+	Positive Input to Charge Pump
2	2	SQ <sub>OUT</sub>	Buffered Square Wave Output Signal
3	3	FREQ <sub>IN</sub>	Speed or RPM Input Signal
4-7, 14-17	4, 5, 12, 13	GND	Ground
8	6	COS+	Positive Cosine Output Signal
9	7	COS-	Negative Cosine Output
10	8	VCC	Ignition or Battery Supply Voltage
11	9	BIAS	Test Point or Zero Adjustment
12	10	SIN-	Negative Sine Output Signal
13	11	SIN+	Positive Sine Output Signal
18	14	VREG	Voltage Regulator Output
19	15	F/V <sub>OUT</sub>	Output Voltage Proportional to Input Signal Frequency
20	16	CP-	Negative Input to Charge Pump

BLOCK DIAGRAM

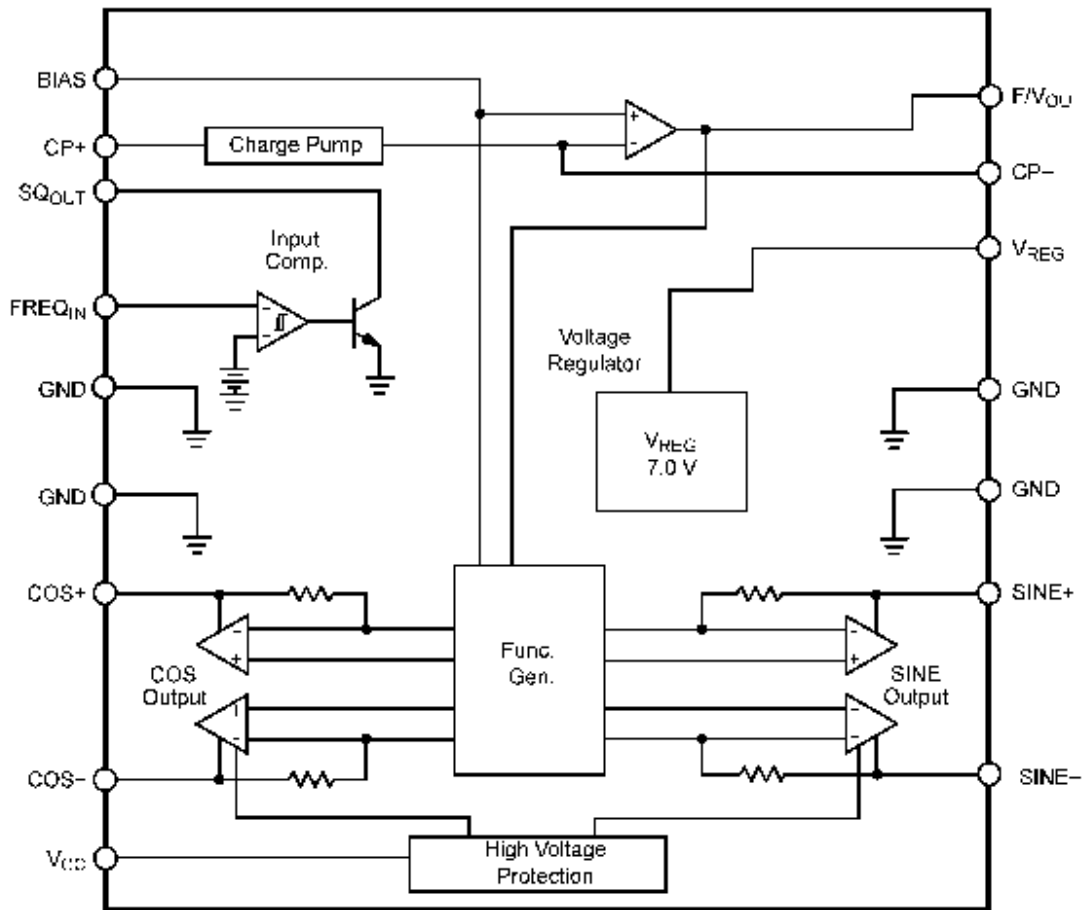

**ELECTRICAL CHARACTERISTICS**

$-40^{\circ}\text{C} \leq T_A \leq 85^{\circ}\text{C}$ ,  $8.5\text{V} \leq V_{CC} \leq 16\text{V}$ , unless otherwise noted.

PARAMETER	SYMBOL	TEST CONDITIONS	MIN	TYP	MAX	UNIT
<b>SUPPLY VOLTAGE SECTION</b>						
Supply Current	$I_{CC}$	$V_{CC} = 16\text{V}$ , $-40^{\circ}\text{C}$ , No Load	-	66	125	mA
Normal Operation Range	$V_{CC}$		8.5	13.1	16	V
<b>INPUT COMPARATOR SECTION</b>						
Positive Input Threshold	$V_{TH}$		1.0	2.1	3.0	V
Input Hysteresis	$V_{HYS}$		200	470	-	mV
Input Bias Current <sup>(Note 3)</sup>	$I_{IB1}$	$0\text{V} \leq V_{IN} \leq 8.0\text{V}$	-	$\pm 4$	$\pm 80$	$\mu\text{A}$
Input Frequency Range	$F_{IN}$		0	-	20	kHz
Input Voltage Range	$V_{IN}$	In series with $1.0\text{k}\Omega$	-1.0	-	$V_{CC}$	V
Output Saturation Voltage	$V_{SAT}$	$I_O = 10\text{mA}$	-	0.1	0.4	V
Output Leakage Current	$I_L$	$V_O = 7.0\text{V}$	-	0.02	10	$\mu\text{A}$
Low $V_{CC}$ Disable Threshold	$V_{CC\_TH}$		7.0	8.0	8.5	V
Logic Zero Input Voltage	$V_{IL}$		1.0	1.6	-	V
<b>VOLTAGE REGULATOR SECTION</b>						
Output Voltage	$V_{REF}$		6.25	7.00	7.50	V
Output Load Current	$I_O$		-	-	10	mA
Output Load Regulation	LDR	0 to 10mA	-	4.0	50	mV
Output Line Regulation	LNR	$8.5\text{V} \leq V_{CC} \leq 16\text{V}$	-	30	150	mV
Power Supply Rejection	PSRR	$V_{CC} = 13.1\text{V}$ , $1.0V_{PP}$ , $1.0\text{kHz}$	34	46	-	dB
<b>CHARGE PUMP SECTION</b>						
Inverting Input Voltage	$V_{IN\_INV}$		1.5	2.1	2.5	V
Input Bias Current	$I_{IB2}$		-	35	150	nA
VBIAS Input Voltage	$V_{BIAS}$		1.5	2.1	2.5	V
Non Inverting Input Voltage	$V_{IN\_NINV}$	$I_{IN} = 1.0\text{mA}$	-	0.6	1.1	V
Linearity <sup>(Note 4)</sup>	$L_K$	@ 0, 87.5, 175, 262.5, 350Hz	-0.10	0.28	0.70	%
F/ $V_{OUT}$ Gain	K	@ 350Hz, $C_{CP} = 0.0033\mu\text{F}$ , $R_T = 243\text{k}\Omega$	7.0	10.5	13	mV/Hz
Norton Gain, Positive	$G_{INP}$	$I_{IN} = 15\mu\text{A}$	0.9	1.0	1.1	I/I
Norton Gain, Negative	$G_{INN}$	$I_{IN} = 15\mu\text{A}$	0.9	1.0	1.1	I/I

Note 3. Input is clamped by and internal 12V Zener.

Note 4. Applies to % of full scale ( $270^{\circ}$ ).

**ELECTRICAL CHARACTERISTICS** (continued)

$-40^{\circ}\text{C} \leq T_A \leq 85^{\circ}\text{C}$ ,  $V_{CC} = 13.1\text{V}$ , unless otherwise noted.

PARAMETER	SYMBOL	TEST CONDITIONS	MIN	TYP	MAX	UNIT
FUNCTION GENERATOR SECTION						
Return to Zero Threshold	$V_{CC\_TH}$	$T_A = 25^{\circ}\text{C}$	5.2	6.0	7.0	V
Differential Drive Voltage ( $V_{COS+} - V_{COS-}$ )		$8.5\text{V} \leq V_{CC} \leq 16\text{V}$ , $\theta = 0^{\circ}$	5.5	6.5	7.5	V
Differential Drive Voltage ( $V_{SIN+} - V_{SIN-}$ )		$8.5\text{V} \leq V_{CC} \leq 16\text{V}$ , $\theta = 90^{\circ}$	5.5	6.5	7.5	V
Differential Drive Voltage ( $V_{COS+} - V_{COS-}$ )		$8.5\text{V} \leq V_{CC} \leq 16\text{V}$ , $\theta = 180^{\circ}$	-7.5	-6.5	-5.5	V
Differential Drive Voltage ( $V_{SIN+} - V_{SIN-}$ )		$8.5\text{V} \leq V_{CC} \leq 16\text{V}$ , $\theta = 270^{\circ}$	-7.5	-6.5	-5.5	V
Differential Drive Current	$I_{OUT}$	$8.5\text{V} \leq V_{CC} \leq 16\text{V}$	-	33	42	mA
Zero Hertz Output Angle	$\theta$		-1.5	0	1.5	deg
Function Generator Error <sup>(Note 5)</sup>		$V_{CC} = 13.1\text{V}$ , $\theta = 0^{\circ}$ to $305^{\circ}$	-2.0	0	2.0	deg
Function Generator Error		$13.1\text{V} \leq V_{CC} \leq 16\text{V}$	-2.5	0	2.5	deg
Function Generator Error		$13.1\text{V} \leq V_{CC} \leq 11\text{V}$	-1.0	0	1.0	deg
Function Generator Error		$13.1\text{V} \leq V_{CC} \leq 9.0\text{V}$	-3.0	0	3.0	deg
Function Generator Error		$25^{\circ}\text{C} \leq T_A \leq 80^{\circ}\text{C}$	-3.0	0	3.0	deg
Function Generator Error		$25^{\circ}\text{C} \leq T_A \leq 105^{\circ}\text{C}$	-5.5	0	5.5	deg
Function Generator Error		$-40^{\circ}\text{C} \leq T_A \leq 25^{\circ}\text{C}$	-3.0	0	3.0	deg
Function Generator Gain		$T_A = 25^{\circ}\text{C}$ , $\theta$ vs $F/V_{OUT}$	60	77	95	$^{\circ}/\text{V}$

Note 5. Deviation from nominal per Table 1 after calibration at  $0^{\circ}$  and  $270^{\circ}$ . Reference Figures 1, 2, 3, 4.

TYPICAL OPERATING CHARACTERISTICS

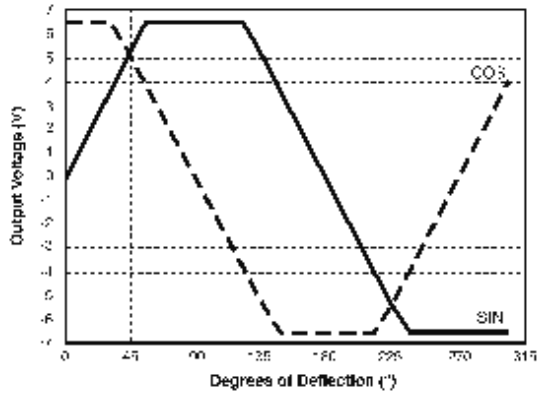

Figure 1. Function Generator Output Voltage vs. Degrees of Deflection

$$F / V_{OUT} = 2.0V + 2 \text{ FREQ} \times C_T \times R_T \times (V_{REG} - 0.7V)$$

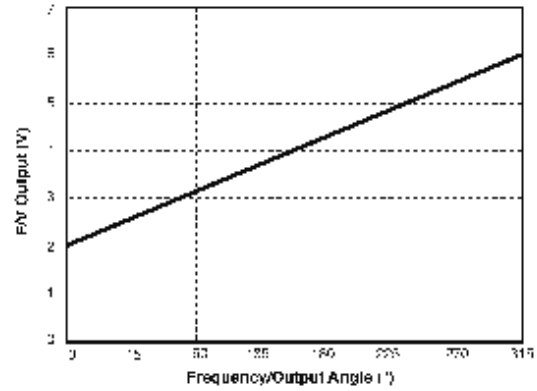

Figure 2. Charge Pump Output Voltage vs. Output Angle

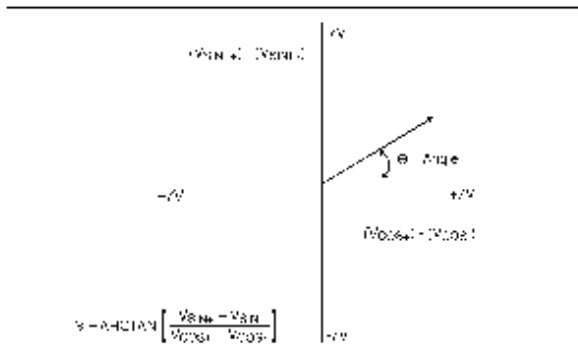

Figure 3. Output Angle in Polar Form

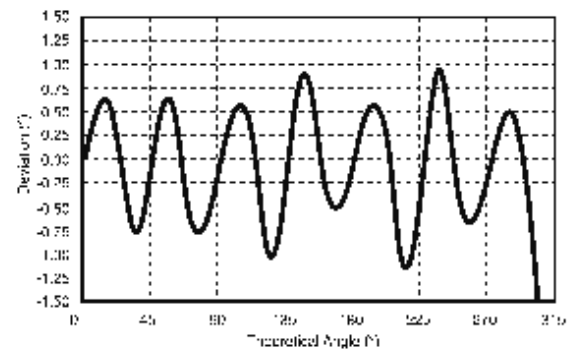
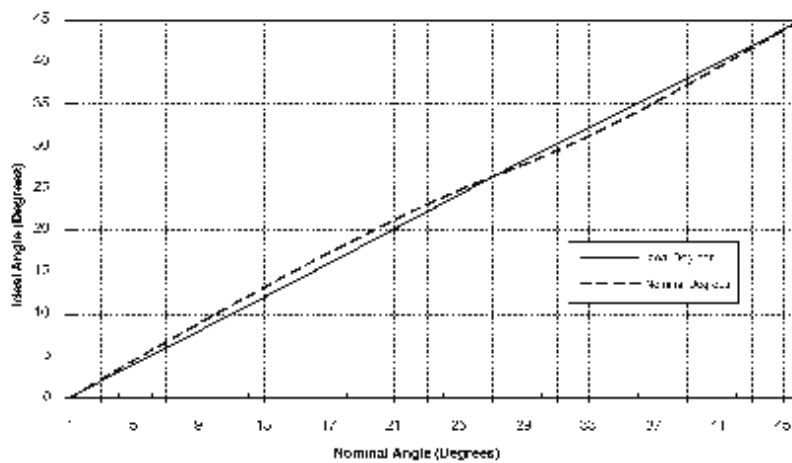

Figure 4. Nominal Output Deviation



Note: Temperature, voltage, and nonlinearity not included.

Figure 5. Nominal Angle vs. ideal Angle (After Calibrating at 180°)

Table 1. Function Generator Output Nominal Angle vs. Ideal Angle (After Calibrating at 270°)

Ideal Degrees	Nominal H Degrees	Ideal Degrees	Nominal H Degrees	Ideal Degrees	Nominal H Degrees	Ideal Degrees	Nominal H Degrees	Ideal Degrees	Nominal H Degrees	Ideal Degrees	Nominal H Degrees
0	0	17	17.98	34	33.04	73	74.00	160	159.14	243	244.63
1	1.09	18	18.96	35	34.00	80	79.16	165	164.00	250	249.14
2	2.19	19	19.92	36	35.00	85	84.53	170	169.16	255	254.00
3	3.29	20	20.86	37	36.00	90	90.00	175	174.33	260	259.16
4	4.38	21	21.79	38	37.11	95	95.47	180	180.00	265	264.53
5	5.47	22	22.71	39	38.21	100	100.64	185	185.47	270	270.00
6	6.56	23	23.61	40	39.32	105	106.00	190	190.84	275	275.47
7	7.64	24	24.50	41	40.45	110	110.86	195	196.00	280	280.84
8	8.72	25	25.37	42	41.59	115	115.37	200	200.86	285	286.00
9	9.78	26	26.23	43	42.73	120	119.56	205	205.37	290	290.56
10	10.84	27	27.07	44	43.88	125	124.00	210	209.56	295	295.37
11	11.90	28	27.79	45	45.00	130	129.37	215	214.00	300	299.21
12	12.94	29	28.73	50	50.68	135	135.00	220	219.32	305	303.02
13	13.97	30	29.56	55	56.00	140	140.68	225	225.00		
14	14.99	31	30.38	60	60.44	145	146.00	230	230.58		
15	16.00	32	31.24	65	64.63	150	150.14	235	236.00		
16	17.00	33	32.12	70	69.14	155	154.63	240	240.44		

Note: Temperature, voltage, and nonlinearity not included.

## CIRCUIT DESCRIPTION AND APPLICATION NOTES

The CS8190 is specifically designed for use with air-core meter movements. It includes an input comparator for sensing an input signal from an ignition pulse or speed sensor, a charge pump for frequency to voltage conversion, a bandgap voltage regulator for stable operation, and a function generator for stable operation, and a function generator with sine and cosine amplifiers to differentially drive the meter coils.

From the partial schematic of Figure 6, the input signal is applied to the  $FREQ_{IN}$  lead, this is the input to a high impedance comparator with a typical positive input threshold of 2.0V and typical hysteresis of 0.5V. The output of the comparator,  $SQ_{OUT}$ , is applied to the charge pump input  $CP+$  through an external capacitor  $C_{CP}$ . When the input signal changes state,  $C_{CP}$  is charged or discharged through  $R3$  and  $R4$ . The charge accumulated on  $C_{CP}$  is mirrored to  $C4$  by the Norton Amplifier circuit comprising of  $Q1$ ,  $Q2$  and  $Q3$ . The charge pump output voltage,  $F/V_{OUT}$ , ranges from 2.0V to 6.3V depending on the input signal frequency and the gain of the charge pump according to the formula:

$$F/V_{OUT} = 2.0V + 2.0 \times FREQ \times C_{CP} \times R_T \times (V_{REG} - 0.7V)$$

$R_T$  is a potentiometer used to adjust the gain of the F/V output stage and give the correct meter deflection. The F/V output voltage is applied to the function generator which generates the sine and cosine output voltages. The output voltage of the sine and cosine amplifiers are derived from the on-chip amplifier and function generator circuitry. The various trip points for the circuit (i.e., 0°, 90°, 180°, 270°) are determined by an internal resistor divider and the bandgap voltage reference. The coils are differentially drive, allowing bidirectional current flow in the outputs, thus providing up to 305° range of meter deflection. Driving the coils differentially offers faster response time, higher current capability, higher output voltage swings, and reduced external component count. The key advantage is a higher torque output for the pointer.

The output angle,  $\theta$ , is equal to the F/V gain multiplied by the function generator gain:

$$\theta = A_{F/V} \times A_{FG}$$

where:

$$A_{FG} = 77^\circ/V \text{ (typ)}$$

The relationship between input frequency and output angle is;

$$\theta = A_{FG} \times 2.0 \times FREQ \times C_{CP} \times R_T \times (V_{REG} - 0.7V)$$

or,

$$\theta = 970 \times FREQ \times C_{CP} \times R_T$$

The ripple voltage at the F/V converter's output is determined by the ratio of  $C_{CP}$  and  $C4$  in the formula:

$$\Delta V = \frac{C_{CP} (V_{REG} - 0.7)}{C4}$$

Ripple voltage on the F/V output causes pointer or needle flutter especially at low input frequencies.

The response time of the F/V is determined by the time constant formed by  $R_T$  and  $C4$ . Increasing the value of  $C4$  will reduce the ripple on the F/V output but will also increase the response time. An increase in response time causes a very slow meter movement and may be unacceptable for many applications.

The CS8190 has an under-voltage detect circuit that disables the input comparator when  $VCC$  falls below 8.0V (typical). With no input signal the F/V output voltage decreases and the needle moves towards zero. A second



under-voltage detect circuit at 6.0V (typical) causes the function generator to generate a differential SIN drive voltage of zero volts and the differential COS drive voltage to go as high as possible. This combination of voltages (Figure 1) across the meter coil moves the needle to the 0° position. Connecting a large capacitor (> 2,000 μF) to the V<sub>CC</sub> lead (C2 in the Figure 8) increases the time between these under-voltage points since the capacitor discharges slowly and ensures that the needle moves towards 0° as opposed to 360°. The exact value of the capacitor depends on the response time of the system, the maximum meter deflection and the current consumption of the circuit. It should be selected by bread-boarding the design in the lab.

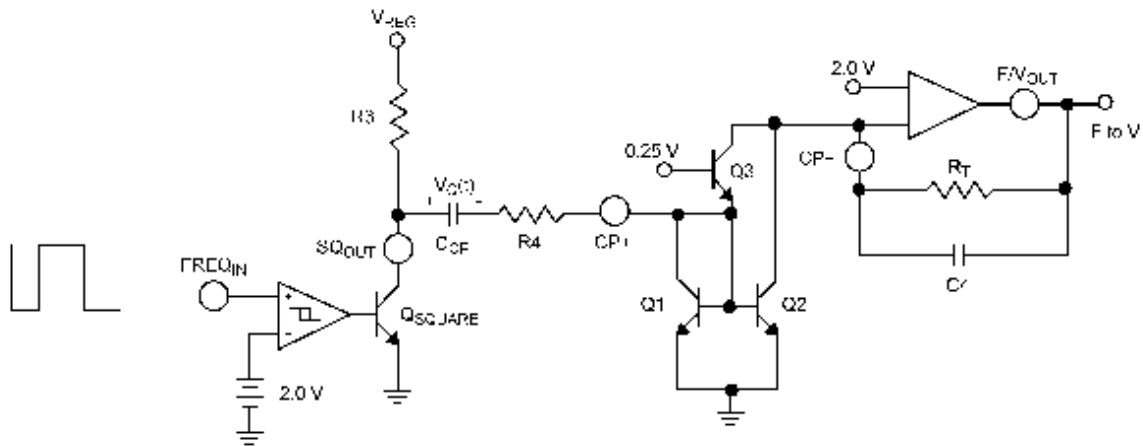

Figure 6. Partial Schematic of Input and Charge Pump

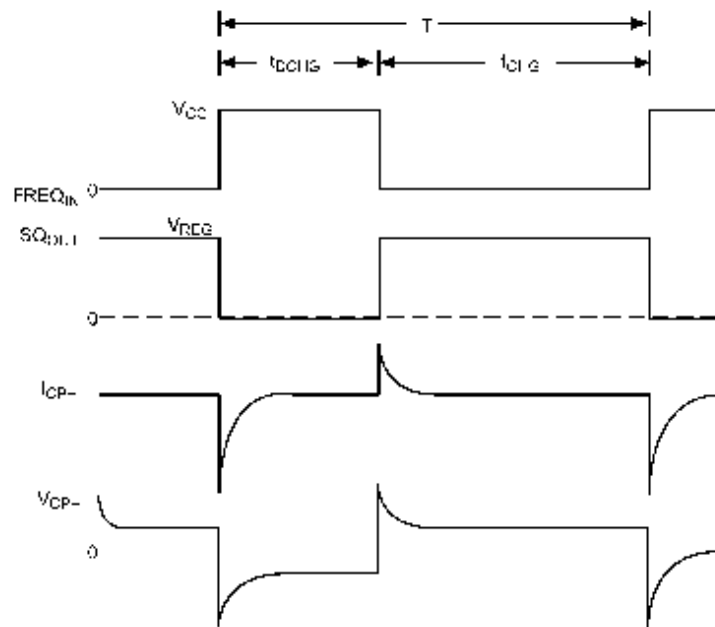
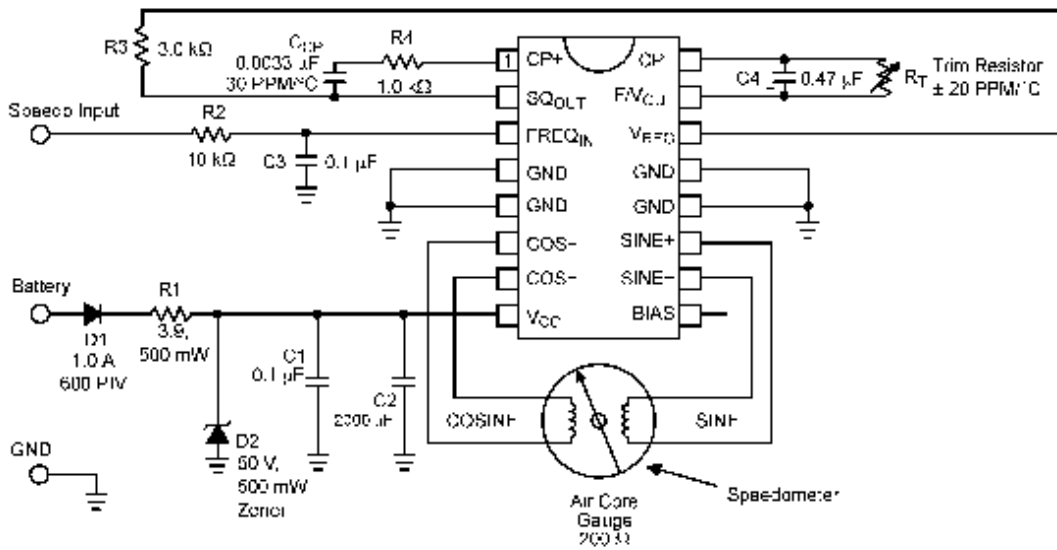

Figure 7. Timing Diagram of FREQ<sub>IN</sub> and I<sub>CP</sub>



Notes:

1. C2 (> 2,000 μF) is needed if return to zero function is required.
2. The product of C<sub>CP</sub> and R<sub>T</sub> have a direct effect on the transfer function (f to V conversion) and therefore directly affect temperature compensation.
3. C<sub>CP</sub> Range: 20 pF to 0.2 μF
4. R<sub>T</sub> Range: 100 kΩ to 500 kΩ.
5. The IC must be protected from transients above 60V and reverse battery conditions.
6. Additional filtering on the FREQ<sub>IN</sub> lead may be required.
7. Gauge coil connections to the IC must be kept as short as possible (≤ 3.0 inch) for best pointer stability.

Figure 8. Speedometer or Tachometer Application

**DESIGN EXMAPLE**

Maximum Meter Deflection = 270°

Maximum Input Frequency = 350 Hz

1. Select R<sub>T</sub> and C<sub>CP</sub>

$$\Theta = 970 \times \text{FREQ} \times C_{CP} \times R_T = 270^\circ$$

Let C<sub>CP</sub> = 0.0033 μF, find R<sub>T</sub>

$$R_T = \frac{270^\circ}{970 \times 350 \text{ Hz} \times 0.0033 \mu\text{F}}$$

$$R_T = 243 \text{ k}\Omega$$

R<sub>T</sub> should be a 250 kΩ potentiometer to trim out any inaccuracies due to IC tolerances or meter movement pointer placement.

2. Select R3 and R4

Resistor R3 sets the output current from the voltage regulator. The maximum output current from the voltage regulator is 10mA. R3 must ensure that the current does not exceed this limit.

Choose R3 = 3.3 kΩ.

The charge current for  $C_{CP}$  is

$$\frac{V_{REG} - 0.7V}{3.3\text{ k}\Omega} = 1.90\text{ mA}$$

$C_{CP}$  must charge and discharge fully during each cycle of the input signal. Time for one cycle at maximum frequency is 2.85ms. To ensure that  $C_{CP}$  is charged, assume that the  $(R3+R4)$   $C_{CP}$  time constant is less than 10% of the minimum input period.

$$T = 10\% \times \frac{1}{350\text{ Hz}} = 285\ \mu\text{s}$$

Choose  $R4 = 1.0\text{ k}\Omega$ .

Discharge time:  $t_{DCHG} = R3 \times C_{CP} = 3.3\text{ k}\Omega \times 0.0033\ \mu\text{F} = 10.9\ \mu\text{s}$

Charge time:  $t_{CHG} = (R3 + R4) C_{CP} = 4.3\text{ k}\Omega \times 0.0033\ \mu\text{F} = 14.2\ \mu\text{s}$

3. Determine  $C4$

$C4$  is selected to satisfy both the maximum allowable ripple and response time of the meter movement.

$$C4 = \frac{C_{CP} (V_{REG} - 0.7V)}{\Delta V_{MAX}}$$

With  $C4 = 0.47\ \mu\text{F}$ , the F/V ripple voltage is 44 mV.

The last component to be selected is the return to zero capacitor  $C2$ . This is selected by increasing the input signal frequency to its maximum so the pointer is at its maximum deflection, then removing the power from the circuit.  $C2$  should be large enough to ensure that the pointer always returns to the 0° position rather than 360° under all operating conditions.

In some cases a designer may wish to use the CS8190 only as a driver for an air-core meter having performed the F/V conversion elsewhere in the circuit.

Figure 9 shows how to drive the CS8190 with a DC voltage ranging from 2.0V to 6.0V this is accomplished by forcing a voltage on the F/V<sub>OUT</sub> lead. The alternative scheme shown in Figure 10 uses an external op amp as a buffer and operates over in input voltage range of 0V to 4.0V.

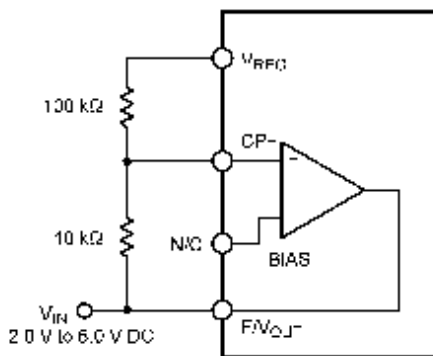

Figure 9. Driving the CS8190 from an External DC Voltage

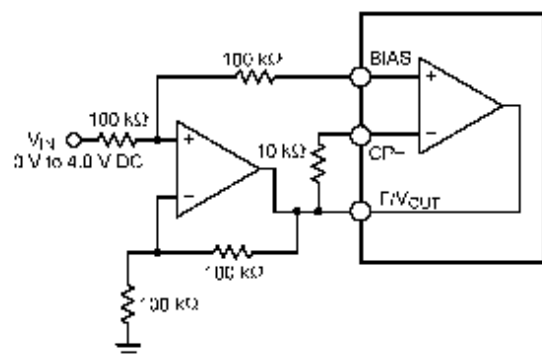

Figure 10. Driving the CS8190 from an External DC Voltage Using an Op Amp Buffer

Figures 9 and 10 are not temperature compensated.

## REVISION NOTICE

The description in this datasheet is subject to change without any notice to describe its electrical characteristics properly.