

Specifications

FM-203	
Model No.	FM-203
Power Consumption	140W
Temperature Range	200-450°C
Temperature Stability	±5°C at idle temperature

Station

Output	24V
Dimensions	120(W) x 120(H) x 190(D)mm
Weight	2.7kg

FM-2027

Model No.	FM-2027
Power Consumption	70W (24V)
Tip to Ground Resistance	< 2Ω
Tip to Ground Potential	< 2mV
Total Length (w/o cord)	188mm with 2.4D tip
Weight (w/o cord)	30g with 2.4D tip
Cord	1.2m

MODEL FM-2022/MODEL FM-2023

Model No.	FM-2022	FM-2023
Power Consumption	140W (24V)	
Temperature Range	200-400°C	
Tip to Ground Resistance	< 2Ω	
Tip to Ground Potential	< 2mV	
Total Length (w/o cord)	148mm with SOP 25L tip	117mm with I tip
Weight (w/o cord)	64g with SOP 25L tip	37g with I tip
Cord	1.2m	

MODEL FM-2024

Model No.	FM-2024
Power Consumption	70W (24V)
Temperature Range	350-450°C
Tip to Ground Potential	< 2mV
Tip to Ground Resistance	< 2Ω
Total Length (w/o cord)	180mm with ø1.0 nozzle
Weight (w/o cord & hose)	65g with ø1.0 nozzle
Cord	1.2m

Desolder Control Box

Power Consumption	12W
Output	24V
Vacuum Generator	Ejector type
Vacuum Pressure (Max.)	93kPa (700mmHg)
Suction Flow	28ℓ/min.
Nozzle to Ground Potential	< 2mV
Applied Air Pressure	490kPa (5.0kgf/cm ²) when in use (trigger or button is pressed)
Compressed Air Consumption	1.62 c.f.m (46ℓ/min.)
Dimensions	119(W) x 45(H) x 172(D)mm
Weight (w/o cord)	1.2kg

Replacement Tips and Nozzles

FM-2027: Please refer to pages 16-17.
MODEL FM-2022, MODEL FM-2023, MODEL FM-2024: Please refer to page 13.

N₂ System



Combination sample with the N₂ system HAKKO FM-203, HAKKO FM-2026, HAKKO FX-780, HAKKO FX-791
* For further details, refer to pages 18-21.

Packing List

Model Name	Contents
HAKKO FM-203	Station1
	Soldering iron (FM-2027)1
	Power cord1
	Iron holder with 599B tip cleaner (No.FH200-01)1
	Control card1
	Connecting cable1
	Tip tray1
	Heat resistant pad1
	* Tip is an optional part.
HAKKO FM-2027 (Conversion kit)	Soldering iron (FM-2027)1
	Iron holder with 599B tip cleaner (No.FH200-01)1
	Connecting cable1
	Heat resistant pad1
	* Tip is an optional part.
HAKKO MODEL FM-2022 (Conversion kit)	Parallel remover (MODEL FM-2022)1
	Iron holder with cleaning sponge (No.FH200-03)1
	Connecting cable1
	Heat resistant pad1
	* Tip is an optional part.
HAKKO MODEL FM-2023 (Conversion kit)	Mini parallel remover (MODEL FM-2023)1
	Tips (T9-I/2pcs of set)1
	Iron holder with cleaning sponge (No.FH200-04)1
	Connecting cable1
	Heat resistant pad1
HAKKO MODEL FM-2024 (Conversion kit)	Desoldering tool (MODEL FM-2024)1
	Desolder control box (DCB)1
	Iron holder with 599B tip cleaner (No.FH200-05)1
	Connecting cable1
	Cleaning drill1
	Ceramic paper filter10
	Filter pipe assembly1
	Handle (for gun configuration)1
	Nozzle remover1

Replacement Parts

Part No.	Name/Description
FM2027-02	Soldering iron FM-2027/Connector assembly 24V-70W
FM2022-02	Parallel remover MODEL FM-2022/24V-140W
FM2023-02	Mini parallel remover MODEL FM-2023/24V-140W
FM2024-02	Desoldering tool MODEL FM-2024/24V-70W
B3216	Sleeve assembly/yellow
B3218	Sleeve assembly/blue
B3217	Sleeve assembly/orange
B3219	Sleeve assembly/ green
599B-02	Tip cleaner
B3253	Connecting cable
A1514	Ceramic paper filter/10 pcs
A1512	Front holder
A1511	Filter pipe assembly
B2756	Tip tray

Replacement Tips and Nozzles

Unit : mm

T16 Series For MODEL FM-2022

* 1set: 2pcs.

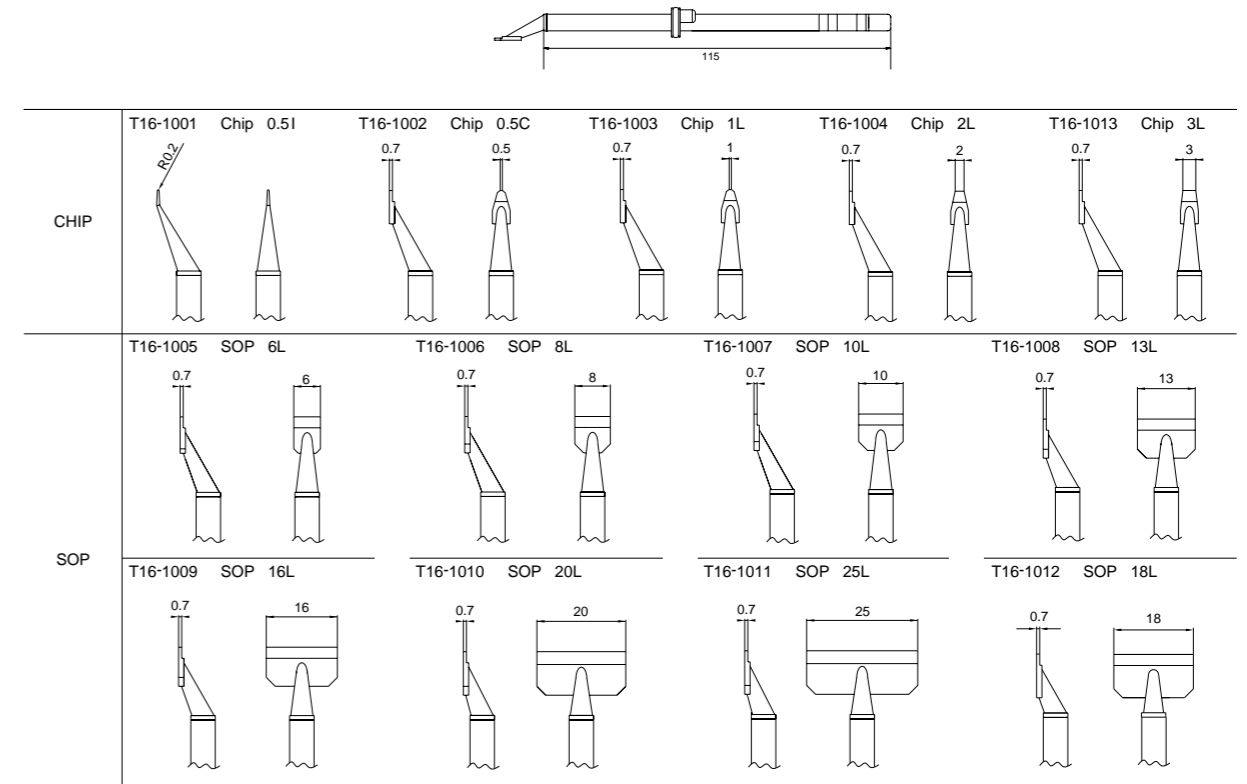

T9 Series For MODEL FM-2023

* 1set: 2pcs.

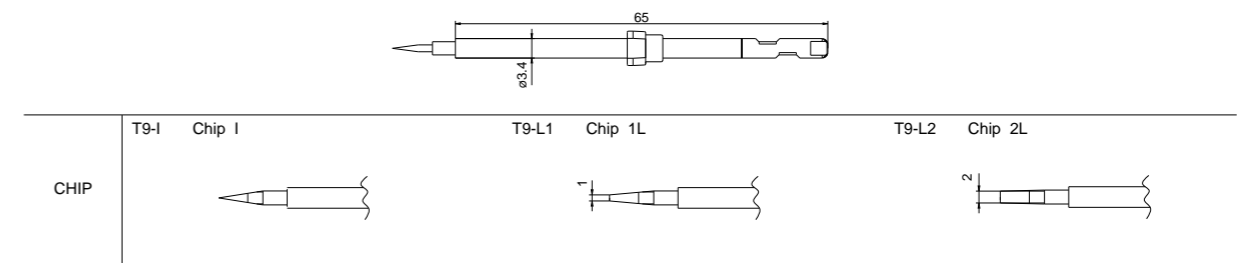

N3 Series For MODEL FM-2024

