

NEW!

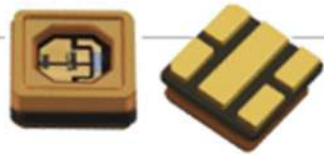

Oasistek®

Bright Ideas. Bright Solutions.

SMT Ultra Violet LED

6V, 200 - 280nm

- Fluorescent spectroscopy
- Sensors and monitors
- Currency detector
- Sterilization and disinfection
- Bioanalysis and detection

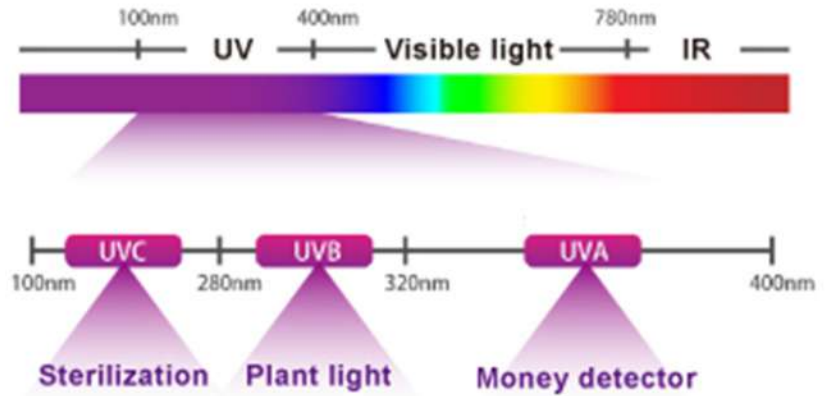

FEATURES:

- High optical output power
- Long life and low light attenuation
- Environmental protection, energy saving, high reliability
- Durable, shock-proof, easy to design, suitable for multi-field applications
- Built-in UVC wavelength chip, unique design, and wide application usage



Part Number	Wavelength λd(nm)	Forward Voltage(V)	Test Condition(mA)	Radiant Flux (mW)	Viewing Angle 2θ1/2
TO-3535BC-UVC265-30-6V-E	265-285	5.6-6.6	30	2.5 - 5	120
TO-3535BC-UVC265-120-6V-E	265-285	5.6-6.6	120	10 - 15	120
TO-3535BC-UVC265-200-6V-E	265-285	5.6-6.6	200	25 - 35	120
TO-3535BC-UVC270-350-6V-E	270-280	6.0-6.8	500	30 - 54	120

Contact your Diverse representative for pricing and samples today!

Contactez votre représentant(e) Diverse pour les prix et les échantillons aujourd'hui!

DIVERSE ELECTRONICS

Shop online at diverseelectronics.com

1-800-381-7308 • sales@diverseelectronics.com

Montreal 514-388-7308 Toronto 647-969-0709

Ottawa 343-550-2722 Vancouver 604-787-8266

TO-3535BC-UVC265-120-6V-E

Surface Mount Device LED

Part Number	Chip		Lens Color
	Material	Source Color	
TO-3535BC-UVC265-120-6V-E	InGaN	Ultra Violet	Water Clear

Features

- High optical output power
- Long life and low light attenuation
- Environmental protection, energy saving and high reliability
- Durable, shock-proof, easy to design, suitable for multi-field applications
- Built-in UVC wavelength chip, unique design and application more widely

Applications

- Fluorescent spectroscopy
- Sensors and monitors
- Currency detector
- Sterilization and disinfection
- Bio-Analysis / Detection



Shop online at diverseelectronics.com

1-800-381-7308 • sales@diverseelectronics.com

Montreal 514-388-7308 Toronto 647-969-0709

Ottawa 343-550-2722 Vancouver 604-787-8266

Dimensions

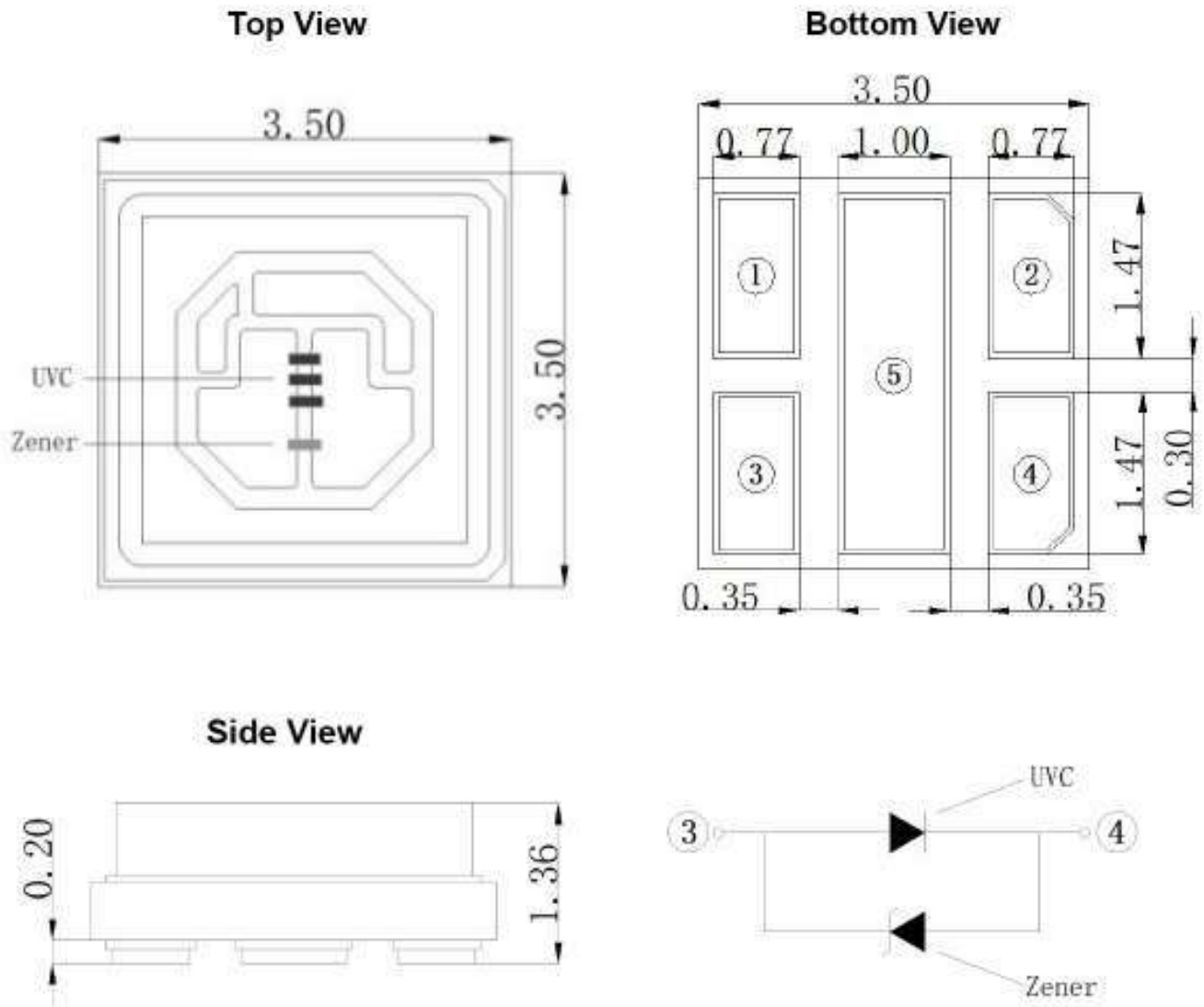

pin1、2、5 NO

Notes:

1. All dimensions are in millimeters.
2. Tolerance is $\pm 0.2\text{mm}$ unless otherwise noted.

Absolute Maximum Rating @ Ta=25°C

Parameter	Maximum Rating	Unit
Power Dissipation	0.792	W
Continuous Forward Current	120	mA
Recommend Operating Current	90	mA
Peak Forward Current (1/10 Duty cycle, 0.1ms pulse width)	240	mA
Reverse Voltage	5	V
Electrostatic Discharge (HBM)	<4K	V
Junction Temperature (Tj)	90	°C
Operating Temperature Range	-30°C to +60°C	
Storage Temperature Range	-30°C to +100°C	
IR Reflow Soldering Profile For Lead Free Soldering	260°C for 10 sec	

Electrical / Optical Characteristic @ Ta=25°C

Parameter	Symbol	Min.	Typ.	Max.	Unit	Test Condition
Radiant Flux	Φ_e	10	-	15	mW	$I_F=120\text{mA}$
Viewing Angle	$2\theta_{1/2}$	-	120	-	deg	$I_F=120\text{mA}$
Peak Wavelength	λ_p	265	-	282.5	nm	$I_F=120\text{mA}$
Forward Voltage	V_F	4.9	-	8.1	V	$I_F=120\text{mA}$
Reverse Current	I_R	-	-	10	μA	$V_R=5\text{V}$
Thermal resistance	$R_{th(j-s)}$	-	10	-	°C/W	$I_F=120\text{mA}$

Notes: Please refer to CIE 1931 chromaticity diagram.

Bin Code List for Reference

Radiant Flux		Unit : mW@120mA
Bin Code	Min	Max
E1	10	15

Tolerance of Radiant Flux on each bin is $\pm 1\%$

Dominant Wavelength		Unit : nm@120mA
Bin Code	Min	Max
265270	265	270
270280	270	280
280282.5	280	282.5

Tolerance of Dominant Wavelength on each bin is $\pm 2\text{nm}$

Forward Voltage		Unit : mcd@120mA
Bin Code	Min	Max
V49	4.9	5.1
V51	5.1	5.3
V53	5.3	5.5
V55	5.5	5.7
V57	5.7	5.9
V59	5.9	6.1
V61	6.1	6.3
V63	6.3	6.5
V65	6.5	6.7
V67	6.7	6.9
V69	6.9	7.1
V71	7.1	7.3
V73	7.3	7.5
V77	7.5	7.7
V79	7.9	8.1

Tolerance for each Forward Voltage Bin is $\pm 0.1\text{V}$

Typical Electrical / Optical Character Curves

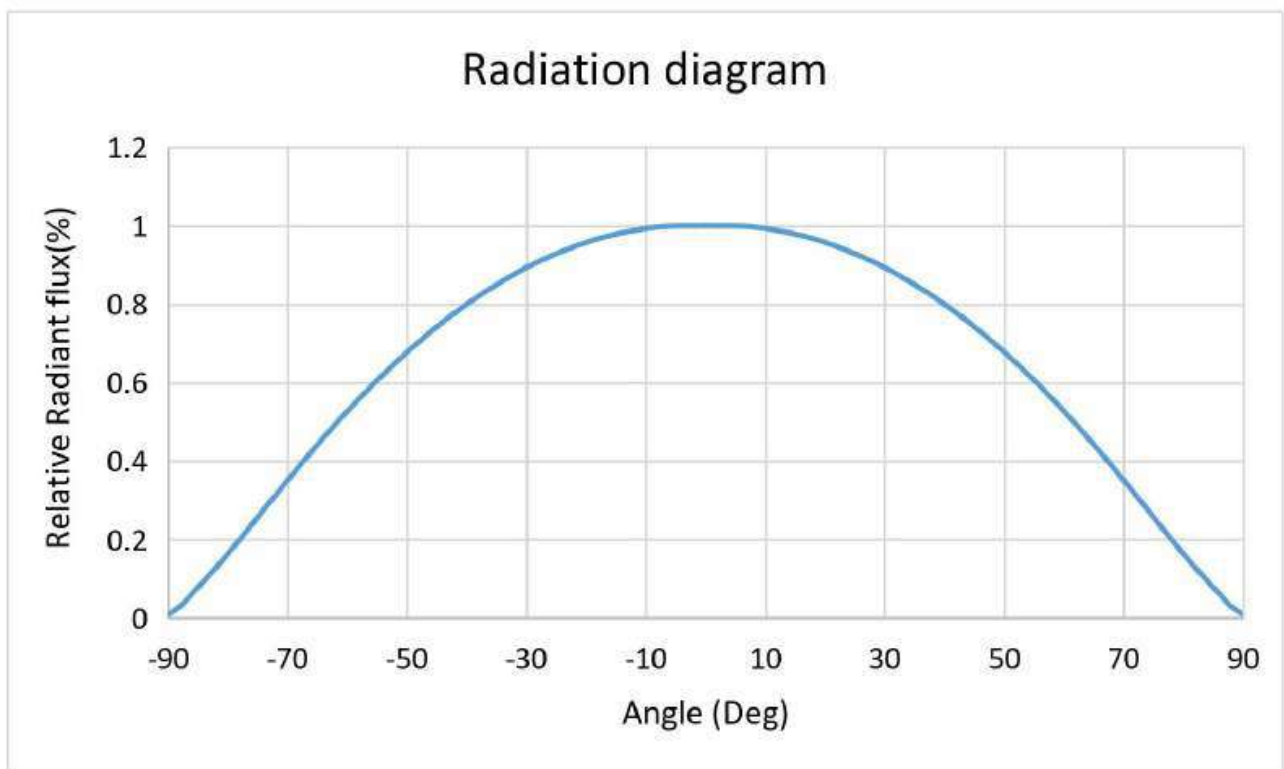
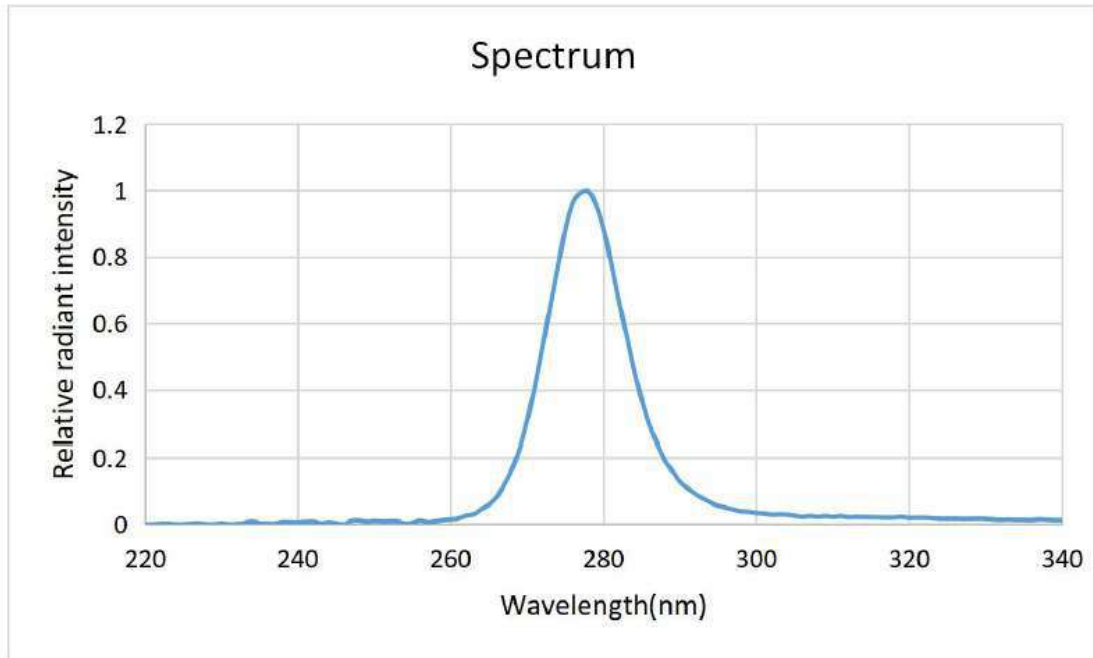

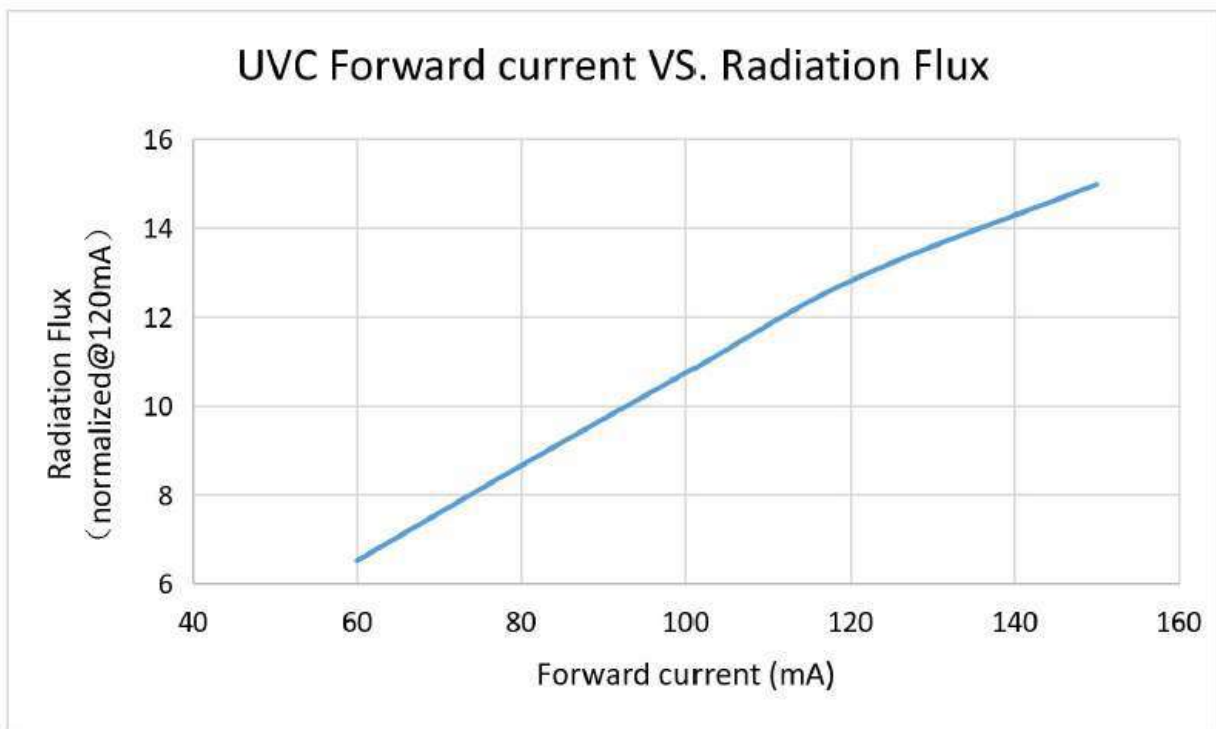
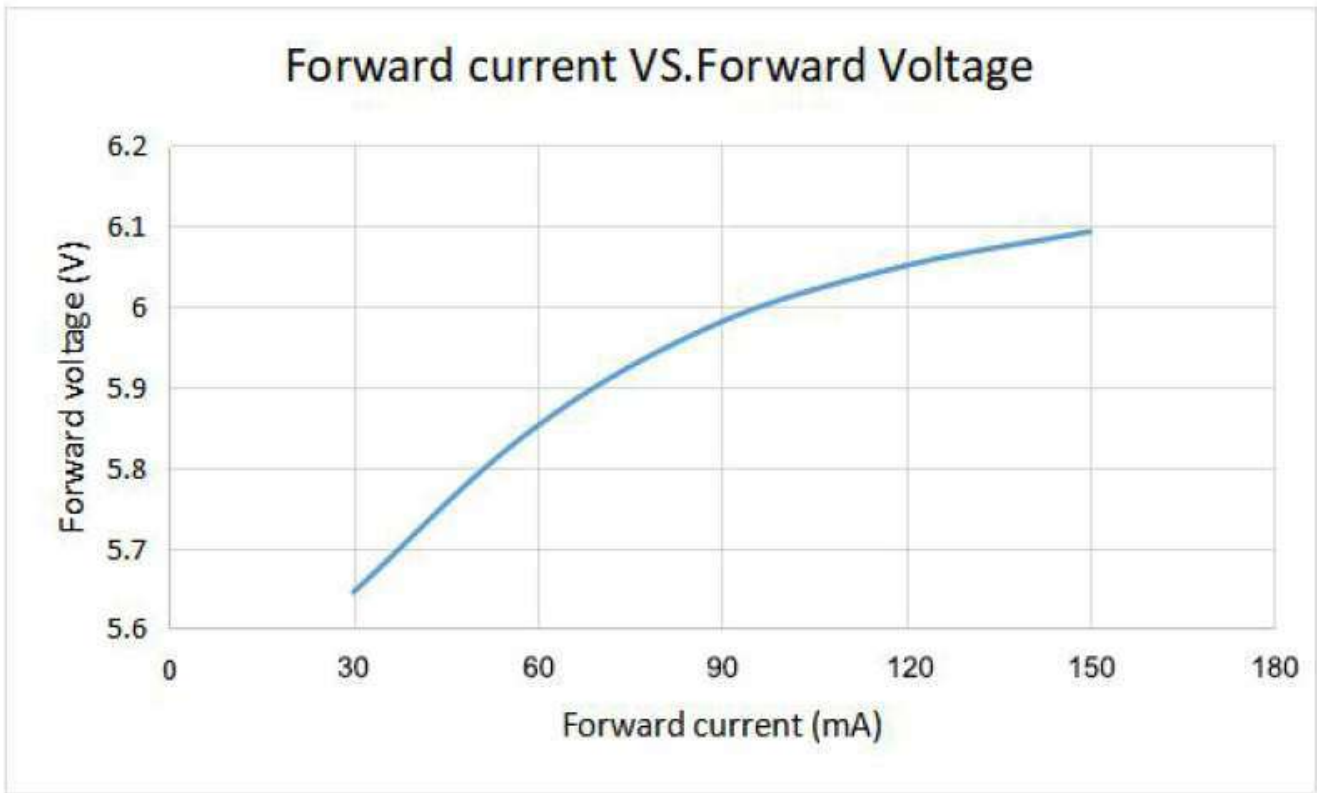

Reflow Profile

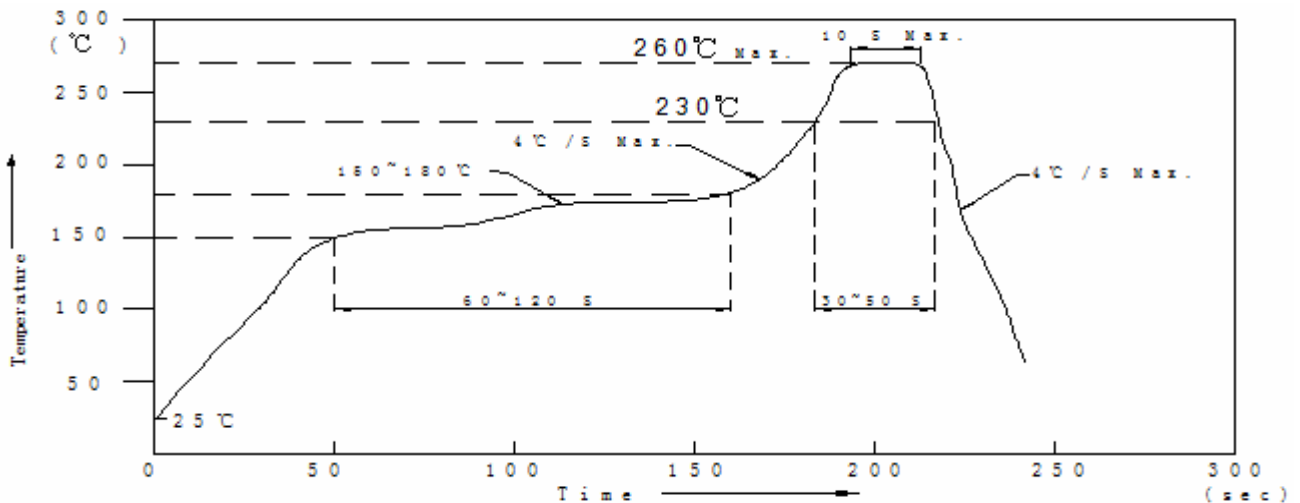

Notes:

1. We recommend the reflow temperature 245°C (±5°C). the maximum soldering temperature should be limited to 260°C.
2. Don't cause stress to the epoxy resin while it is exposed to high temperature.
3. Number of reflow process shall be 2 times or less.

■ Soldering iron

Basic spec is ≤ 5sec when 260°C. If temperature is higher, time should be shorter (+10°C → -1sec). Power dissipation of iron should be smaller than 20W, and temperatures should be controllable. Surface temperature of the device should be under 230°C.

■ Rework

1. Customer must finish rework within 5 sec under 260°C.
2. The head of iron can not touch copper foil
3. Twin-head type is preferred.

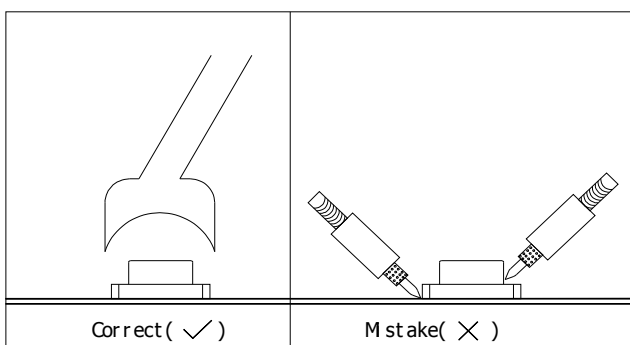

- Avoid rubbing or scraping the resin by any object, during high temperature, for example reflow solder etc.

3535 Series SMD Packaging Specifications

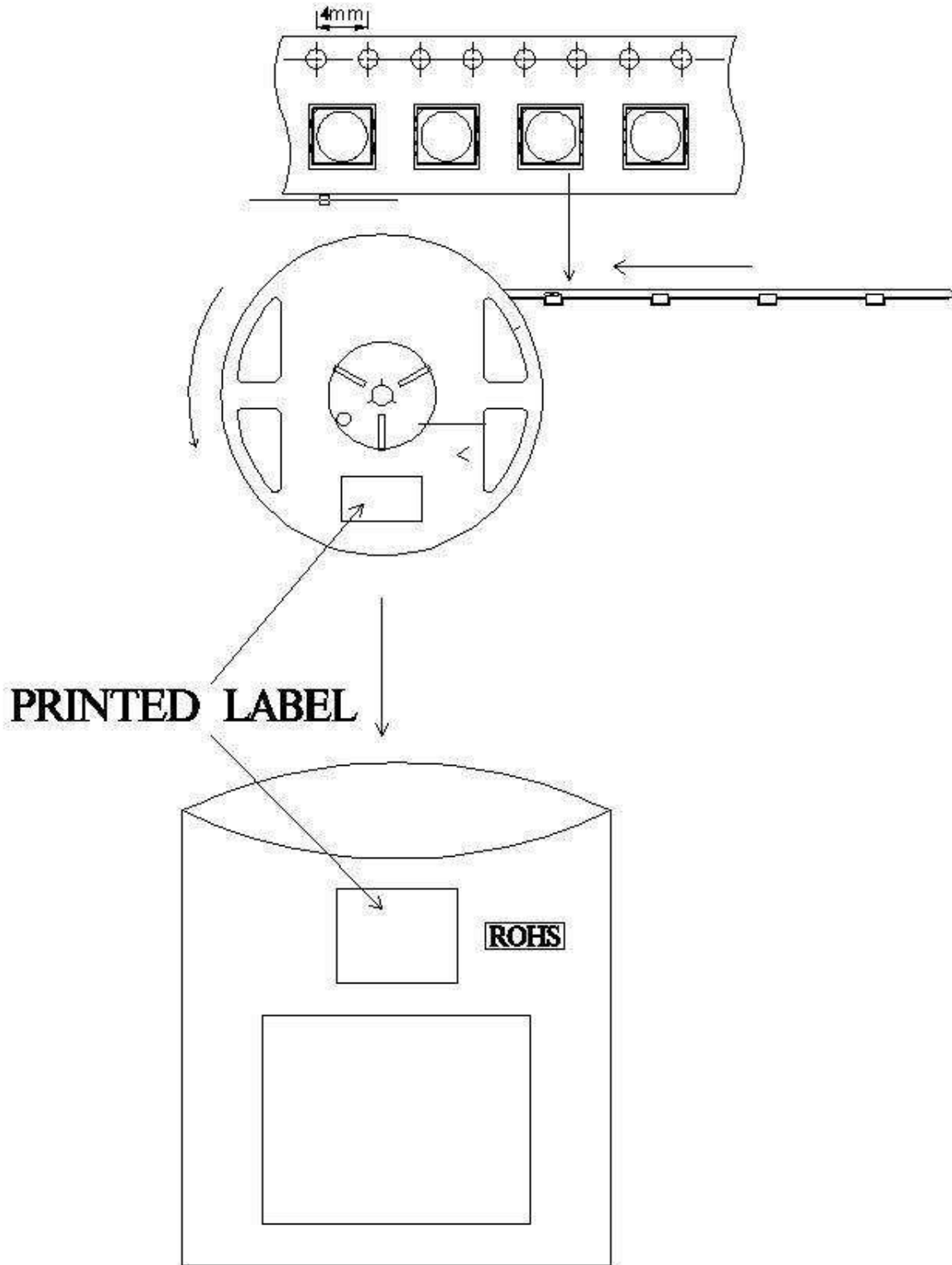

Note : 1000 pcs/Reel.

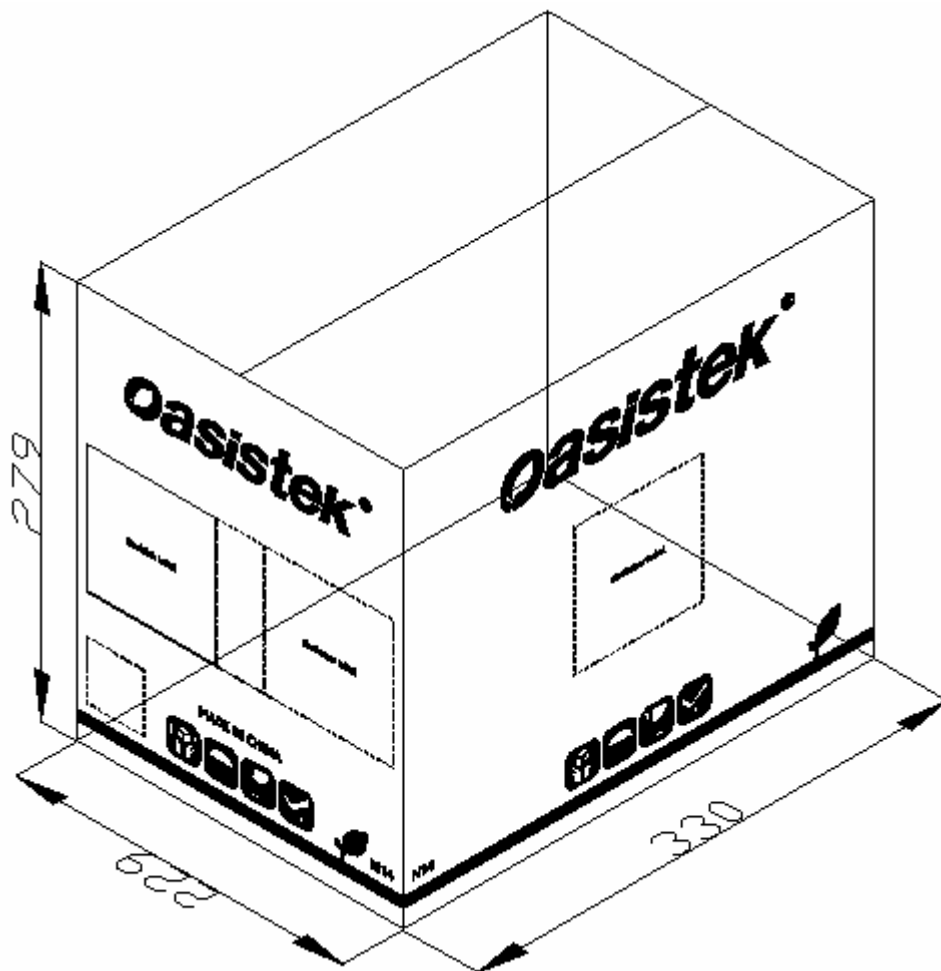
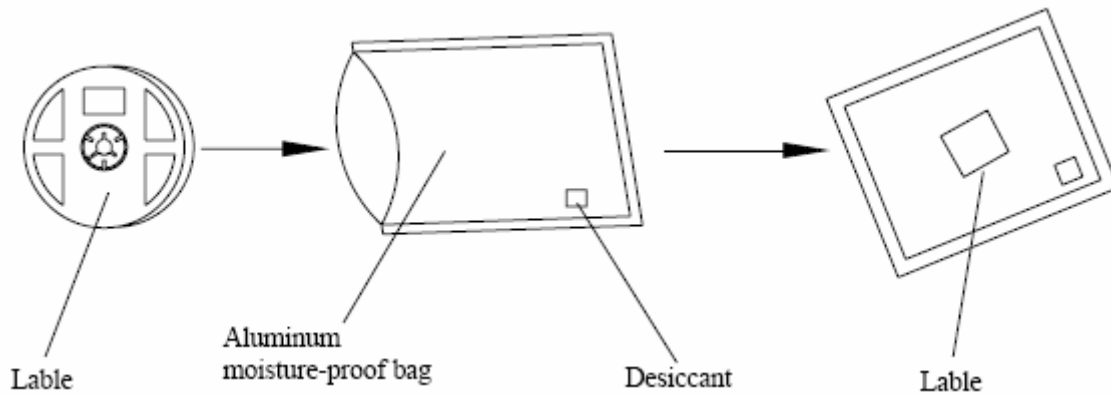

Reliability Tests

Test Item	Test Condition	Test Time
Thermal Shock	-40°C * 10mins ~ 85°C * 10mins	100 cycles
Temperature Humidity Storage	Ta= 85°C, RH= 85%	500hours
High Temperature Storage	Ta= 85°C	500hours
Low Temperature Storage	Ta= -40°C	500hours
DC Operating Life	Ta= 25°C, 120mA	1000hours
Resistance to Soldering Heat IR-Reflow Normal Process	Refer to recommended profile	1 time
Resistance to Soldering Heat IR-Reflow Pb Free Process	Refer to recommended profile	1 time

Cautions

1. Handling Precautions

- Do not handle the LEDs with bare hands as it will contaminate the LENS surface and may affect the optical characteristics.
- When handling the product with tweezers, be careful not to apply excessive force to glass LENS as it may cause the surface scratch.
- Dropping the product may cause damage.

2. Electrostatic Discharge (ESD)

- The product are sensitive to static electricity or surge voltage. ESD can damage a die and its reliability. When handling the products, the following measure against electrostatic discharge are strongly recommended:
Eliminating wrist strap, ESD footwear, clothes, and floors
Grounded workstation equipment and tools
ESD table/shelf mat made of conductive materials
- Ensure that tools, jigs and machines that are being used are properly grounded and that proper grounding techniques are used in work areas. For devices/equipment that mount the LEDs, protection against surge voltages should also be used.
- The customer is advised to check if the LEDs are damage by ESD when performing the characteristics inspection of the LEDs in the application.
Damage can be detected with a forward voltage measurement at low current($\leq 1\text{mA}$).

3. Eye Safety

- Please proceed with caution when handling any UVLEDs driven at low or high current. Since UV light can be harmful to eyes, do not look directly into the UV light, even through an optical instrument.
- UV protective glasses are required to use in order to avoid damage by UV light in case of viewing UV light directly.