

UNLOCK SAVINGS WITH SUPERIOR COMPONENT SOURCING

Benefit from our expertise in sourcing and cost reduction. Contact Diverse Electronics to enhance your procurement strategy.

[SUBMIT AN RFQ TODAY](#)



gesis® DC SOLAR



gesis® DC SOLAR

Connector System
for Solar Power Installations

Solar Power is Pluggable



Pluggable solar solutions from Wieland

At home on both sides

Extremely easy to handle and highly flexible

With Wieland, the enormous benefits of a pluggable electrical installation are no longer restricted to the DC side of photovoltaic systems. Whether for main power supply connections (AC) or connectors for the drives of tracking systems, durable electrical connectors are the backbone of a profitable installation.

The AC solar system

With its 3 and 5 pole connector system RST25i3/i5, Wieland offers the optimal solution for AC side interconnect possibilities. Pre-assembled components and IP68 protection enable a fast and safe installation, even under the most adverse conditions. The RST25i3/i5 AC system includes connectors for on-site field wiring; device connectors for inverter housings (leading manufacturers already deliver their product with RST connectors installed); cable assemblies for connection from the inverter to the combiner box; and combiner boxes that are delivered pre-assembled.

Inverters are often installed in groups, with the same distance between them. The resulting cable lengths repeat from system to system. The AC side can now be installed similarly to the traditional DC module to module interconnection method.

This concept effectively reduces the logistics and installation times to a minimum. This advantage pays

off not only for initial installation, but for any subsequent service or add-on work as well. For servicing, individual inverters can be disconnected from the main supply by simply unplugging them. Continuous protection against accidental contact, as well as quick installation and return to operation ensure a profitable system.

The DC solar system

The DC solar system is developed by Wieland Electric GmbH. The PST 40i1 is based on the need to combine a highly reliable contact system with the easiest termination technology. The silver-plated machined contacts have been proven in the most demanding applications, such as machine tool construction, crane technology, and shipbuilding; they are also ideally suited for wiring in the field. This ease of use is particularly important where the installations are found on rooftops, in building integrated systems, or installations in open space. Just a few individual parts for multiple wire gauge variations and cables simplify logistics at the assembly site.

The IP 68 protection rating, the robust design, as well as the mate compatibility guarantee flexibility for installations. PST 40i1 accepts cross sections of 1.5 mm² up to 10.0 mm², 16 – 8 AWG. This increased wire gauge enables pluggable connections to inverters over extended cable runs. The high current-carrying capacity of 40 A is proof of the contacts' superior conductivity, and at the same time satisfies the trend towards increased input on powerful new string inverters

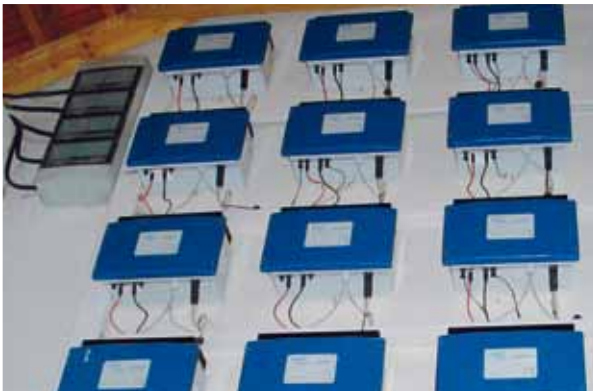

Versions:

AC

RST25i3 for AC single-phase supply

RST20i4 on motors for tracking systems

DC

RST20i2 for parallel connections on thin film modules

PST 40i1 for DC PV modules



The IP68 protection rating, the robust design, as well as the mating compatibility guarantee flexibility for installations. PST40i1 accepts cross sections of 1.5mm² up to 10.0mm², 16 – 8AWG. This increased wire gauge enables pluggable connections to inverters over extended cable runs. The high current-carrying capacity of 40A is proof of the contacts' superior conductivity, and at the same time satisfies the trend towards increased input on powerful new string inverters.

Other areas of applications

- Chargers with a high IP protection requirement
- AC or DC bus in buildings and façades
- Motor connections for tracking systems
- On-board inverters (cars; truck; railroad; RVs; boats)
- Power generation (fuel cells; wind and water power plants; biogas and biomass systems; cogeneration power plants; and geothermal energy systems)

Benefits

- Quick Assembly
- UV Resistant
- Black Polycarbonate
- High Conductivity
- IP68
- 600 VDC / 40 ADC
- Approved to UL 486A-486B No.65-03, UL 486D
- Approved to CSA C22.2 No. 198.2-05



Solar Solutions

Product	Page
DC Connectors	4
DC Cable Assemblies	6
DC Combiner Boxes	8
Residential	10
Commercial	12
Accessories and Tools	14
Technical Information	16
Index	18

Skills that complement one another:

PST40i1 satisfies the most demanding requirements. Not only winning the TÜV certificate or tests at leading institutions provide proof of this, but primarily the daily practical use, taking place worldwide.

DC Solar Connectors

The Photovoltaic DC connectors are the backbone of the total system. It is very important to use a high quality connector to achieve long lasting reliability. Wieland's PST connectors are the best in the industry with silver plated machined contacts and 40 amp DC rating, they are designed to last the life of the system.

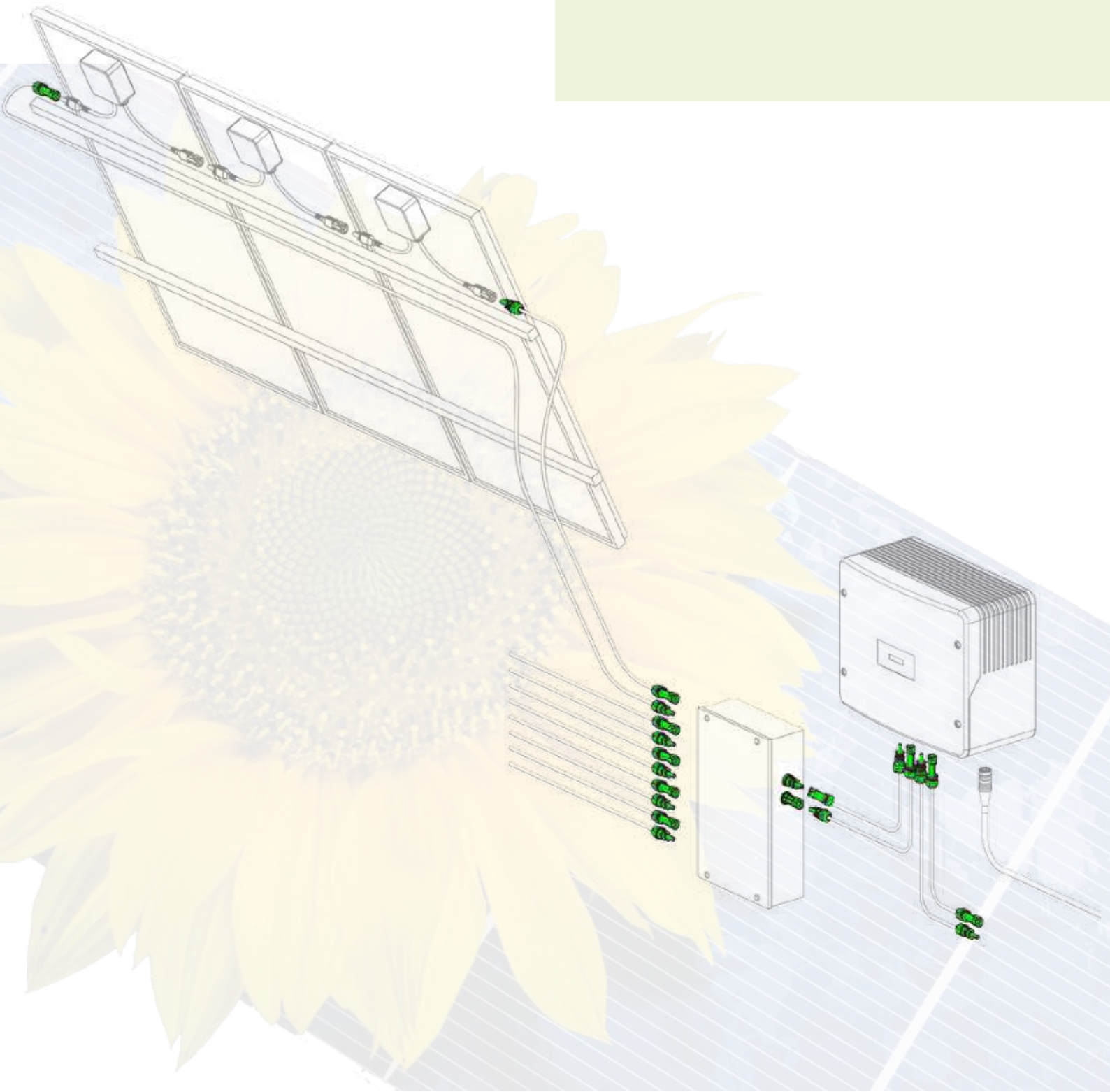

PST 40i1 DC Solar Connectors



PST connectors for field assembly. Fast, easy, installation, crimp contact snaps into housing. The housing is completely touch proof keeping you safe.

- Quick assembly
- UV resistant
- High conductivity
- IP68
- 600 VDC / 40 A
- Approved to UL 486A-486B No.65-03, UL 486D
- Approved to CSA C22.2 No. 198.2-05



PST 40i1 Female



PST 40i1 Male

MODEL	PST 40i1	PST 40i1	PST 40i1	PST 40i1
Type Wire Size Max Voltage Amperage Length Approvals	Female Cable Mount 16 - 8 AWG 600 VDC 40 A 56mm (2 1/4") 	Male Cable Mount 16 - 8 AWG 600 VDC 40 A 59mm (2 1/4") 	Female Panel Mount 16 - 8 AWG 600 VDC 40 A 56mm (2 1/4") 	Male Panel Mount 16 - 8 AWG 600 VDC 40 A 59mm (2 1/4")

	Part Number Model Number	Std. Pack	Part Number Model Number	Std. Pack	Part Number Model Number	Std. Pack	Part Number Model Number	Std. Pack
1 Pole 4-5mm (1/8"-3/16") Cable Gland 	Y6.111.0153.1 PST 40i1 5F	100	Y6.112.0153.1 PST 40i1 5M	100				
1 Pole 5-7mm (3/16"-1/4") Cable Gland 	Y6.111.0053.1 PST 40i1 7F	100	Y6.112.0053.1 PST 40i1 7M	100				
1 Pole 7-8mm (1/4"-3/8") Cable Gland 	Y6.111.0253.1 PST 40i1 8F	100	Y6.112.0253.1 PST 40i1 8M	100				
1 Pole Panel Mount Contacts sold separately 					Y6.111.1053.1 PST 40i1 PF	100	Y6.112.1053.1 PST 40i1 PF	100

Crimp Contacts 1.5mm ² (16 AWG), Unmarked 	02.125.8002.8	100	05.545.2002.8	100	02.125.8002.8	100	05.545.2002.8	100
Crimp Contacts 2.5mm ² (14 AWG), 2 Grooves 	02.125.8102.8	100	05.545.2102.8	100	02.125.8102.8	100	05.545.2102.8	100
Crimp Contacts 4.0mm ² (12 AWG), Unmarked 	02.125.8202.8	100	05.545.2202.8	100	02.125.8202.8	100	05.545.2202.8	100
Crimp Contacts 6.0mm ² (10 AWG), 1 Groove 	02.125.8302.8	100	05.545.2302.8	100	02.125.8302.8	100	05.545.2302.8	100
Crimp Contacts 10.0mm ² (8 AWG), Unmarked 	02.125.8402.8	100	05.545.2402.8	100	02.125.8402.8	100	05.545.2402.8	100

Cover Plug For Connectors 	05.566.6380.0	1	05.566.6480.0	1	05.566.6380.0	1	05.566.6480.0	1
Cover Plug For Connectors - Teather 	Z5.566.6380.0	1	Z5.566.6480.0	1	Z5.566.6380.0	1	Z5.566.6480.0	1
Locking Clip For Mated Connectors 	05.568.2756.0	100	05.568.2756.0	100	05.568.2756.0	100	05.568.2756.0	100

Crimp Tool 	99.630.0000.0	1	99.630.0000.0	1	99.630.0000.0	1	99.630.0000.0	1
Disconnect Tool 	34.250.0015.0	1	34.250.0015.0	1	34.250.0015.0	1	34.250.0015.0	1

Contacts sold separately. Technical Specifications on page 16

Subject to change without notice
www.wieland-electric.ca

DC Solar Cable Assemblies

Wieland now offers pre-built cable assemblies for DC solar installations. These assemblies are built and tested in-house to ensure the best quality. Utilize these cable assemblies to speed up installation time and reduce errors in wiring configurations.

Solar Cable Assemblies will save you money and keep you safe!

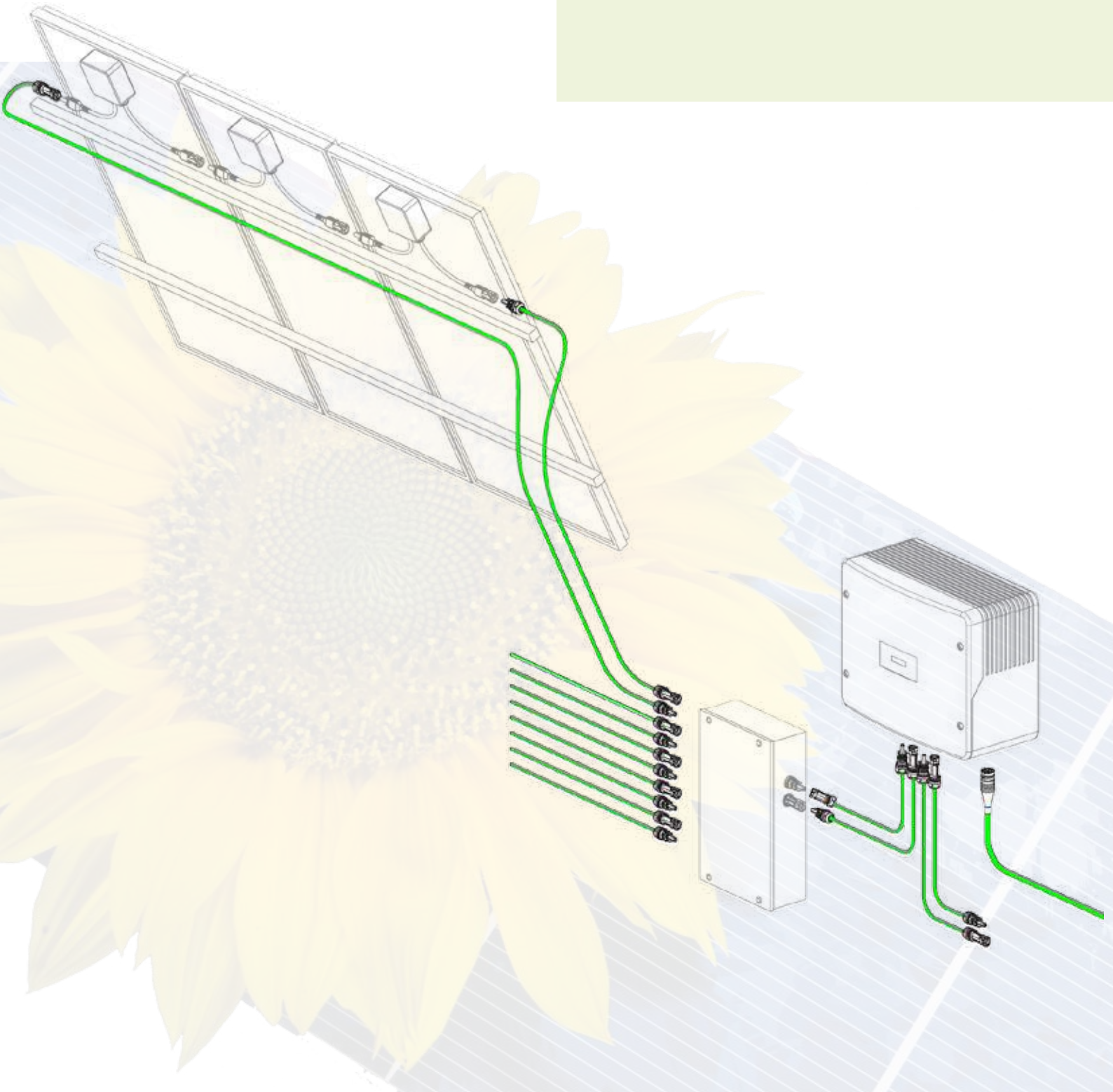

PST 40i1 DC Solar Cable Assemblies



- Fast, errorless installations
- Safe field installations.
- All cable assemblies are tested in-house
- Custom lengths available
- Cost effective time savings
- Prebuilt to specifications
- Simple ordering system
- Reusable

MODEL	PST - PST	PST - PST
Type Wire Type Wire Size Max Voltage Amperage Approvals	PST Male to PST Female Single Insulated Cable 10 AWG 600 VDC 40 A 	PST Male to PST Female Double Insulated Cable 10 AWG 600 VDC 40 A

	Part Number Model Number	Std. Pack	Part Number Model Number	Std. Pack	Part Number Model Number	Std. Pack	Part Number Model Number	Std. Pack
1 Meter (3.28 feet)	34.253.0001.0	1	34.253.0001.1	1				
2 Meters (6.56 feet)	34.253.0002.0	1	34.253.0002.1	1				
5 Meters (16.14 feet)	34.253.0005.0	1	34.253.0005.1	1				
10 Meters (32.81 feet)	34.253.0010.0	1	34.253.0010.1	1				
25 Meters (82 feet)	34.253.0025.0	1	34.253.0025.1	1				
31 Meters (102 feet)	34.253.0031.0	1	34.253.0031.1	1				
50 Meters (164 feet)	34.253.0050.0	1	34.253.0050.1	1				
100 Meters (328 feet)	34.253.0100.0	1	34.253.0100.1	1				

DC Solar Combiner Boxes

The Combiner Box is a critical part of any solar system, usually installed outside and exposed to the weather, it is important to use a high quality combiner box designed to last as long as the PV modules. All of Wieland's DC combiner boxes are manufactured in North America and utilize the highest quality components in the market. Take advantage of Wieland's 100 years of wire interconnect experience to help you design the most robust DC solar system in the market.

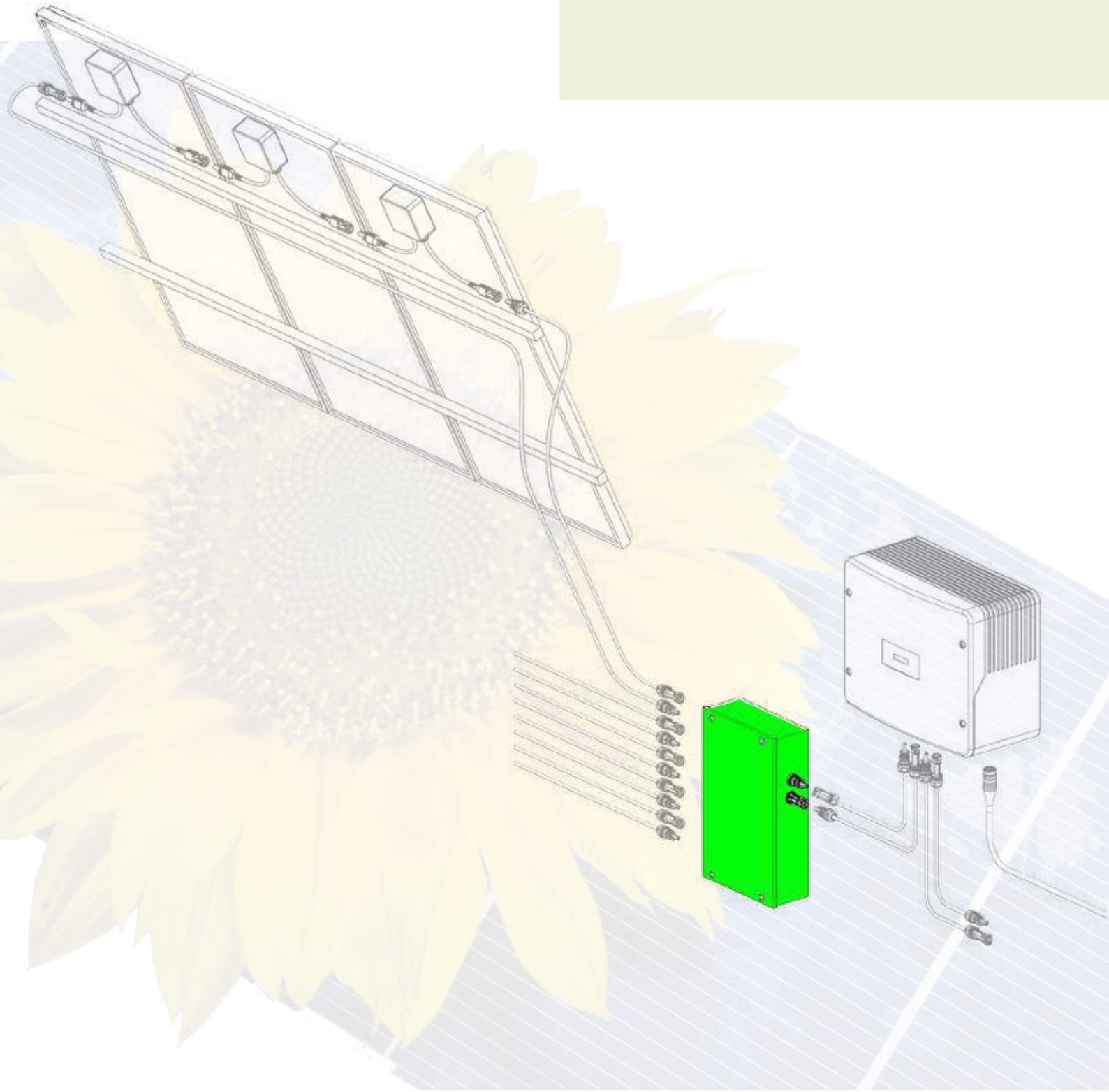

PST 40i1 DC Solar Combiner Boxes



DC Solar Combiner Boxes

The Wieland Solar Combiner Boxes take into account many challenges faced in the Solar Industry today, and specifically in Canada. We recognize that everyone’s needs are not the same and offer custom solutions as well. Our standard products are offered in various string configurations ranging from 2 to 30 strings. There are options such as Surge Protection Devices, DC Disconnects and even String Monitoring.

All of Wieland’s Combiner Boxes include markings and installation instructions. The internal components of the boxes are completely “touch safe” keeping you safe during installation and maintenance. Most of the Combiner Boxes even include the PV Connectors pre-installed; all you have to do is plug into the box. This greatly reduces install time, and when combined with Wieland’s cable sets, it also reduces wiring errors.

The Combiner Boxes are engineered to withstand Canadian winters, and all forms of weather. The boxes are available with NEMA 3R, NEMA 4, and NEMA 4x enclosures, the premium line also includes a Stainless Steel option.

As an example of the engineering standard: The 8 string Combiner Box is rated at 100 Amps DC at 600 Volts DC. Therefore each string input is designed to run at 12.5 Amps DC continuous!

Strings	Small - Residential ABS Enclosure	Small - Commercial Fiberglass Enclosure	Large - Commercial NEMA 3R	Large - Commercial NEMA 4/4x
	600 VDC 30 ADC	600 VDC 50 ADC	600 VDC 64-150 ADC	600 VDC 100 ADC
2	X	X	X	X
5		X	X	X
8			X	X
12			X	
24			X	
30			X	

PST 40i1

2 String DC Residential Solar Combiner Boxes



- 2 String
- Residential combiner box
- High quality components
- NEMA 4x enclosure
- Pre-wired
- Pre-terminated with connectors
- Midget fuse blocks
- Touch safe components



MODEL	DCC-R-2
Type	2 String DC Combiner box ABS Enclosure
Max Voltage	600 VDC
Max Amperage	30 ADC
Approvals	

Basic With Fuse Blocks	Part Number	Std. Pack	Part Number	Std. Pack	Part Number	Std. Pack	Part Number	Std. Pack
	Model Number		Model Number		Model Number		Model Number	
	34.256.0502.5	1						
	DCC-C-8-FG							

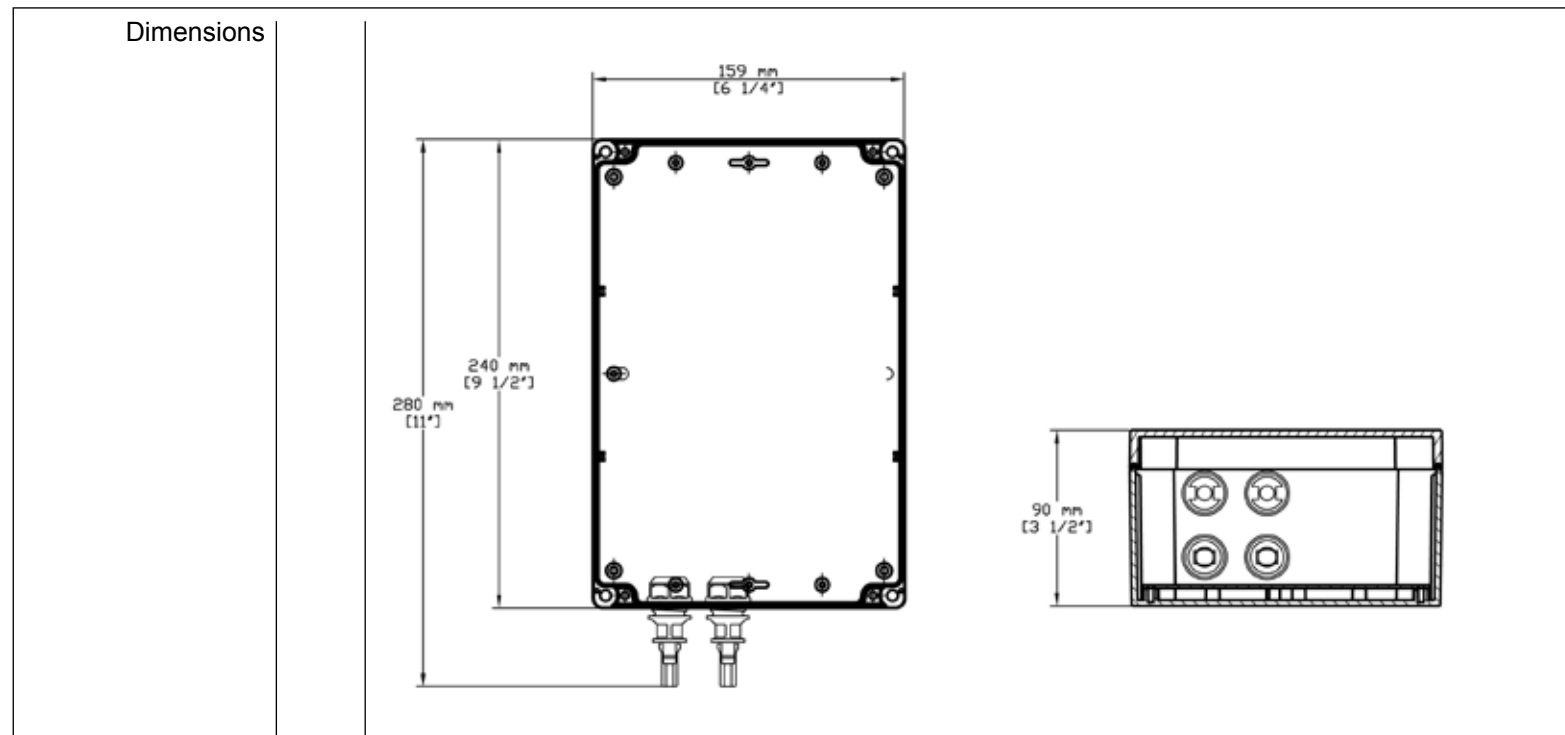

PST 40i1

5 String DC Commercial Solar Combiner Boxes



- 5 String
- Commercial combiner box
- High quality components
- NEMA 4x enclosure
- Pre-wired
- Pre-terminated with connectors
- Midget fuse blocks
- Touch safe components

MODEL	DCC-C-4
Type	5 String DC Combiner box Fiberglass Enclosure
Max Voltage	600 VDC
Max Amperage	50 ADC
Approvals	

Basic With Fuse Blocks							
	Part Number	Std. Pack	Part Number	Std. Pack	Part Number	Std. Pack	Part Number
	Model Number		Model Number		Model Number		Model Number
	34.256.0505.5	1	DCC-C-5-FG				

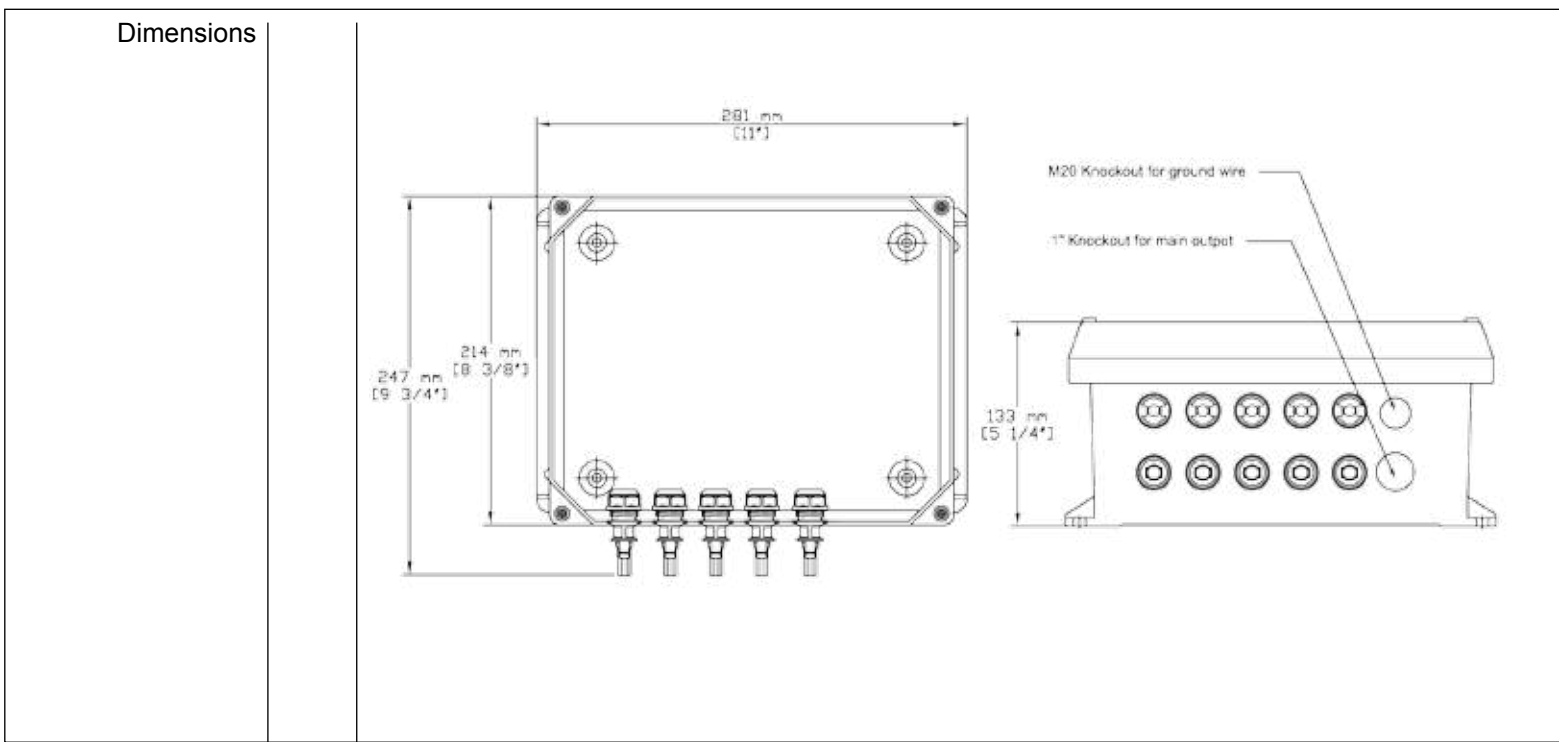

PST 40i1

Basic DC Commercial Solar Combiner Boxes



- 8-30 String
- Commercial combiner box
- NEMA 3R enclosure
- 150 Amp disconnect
- Pre-wired
- Midget fuse blocks
- Touch safe components

MODEL Type	B-DCC-C-8	B-DCC-C-12	B-DCC-C-24	B-DCC-C-30
	8 String DC Combiner box Painted Steel Enclosure	12 String DC Combiner box Painted Steel Enclosure	24 String DC Combiner box Painted Steel Enclosure	30 String DC Combiner box Painted Steel Enclosure
Max Voltage	600 VDC	600 VDC	600 VDC	600 VDC
Max Amperage	64 ADC	96 ADC	132 ADC	150 ADC
Approvals				

	Part Number Model Number	Std. Pack	Part Number Model Number	Std. Pack	Part Number Model Number	Std. Pack	Part Number Model Number	Std. Pack
DC Midget Fuse Blocks	34.136.0002.0	1	34.136.0004.0	1	34.136.0005.0	1	34.136.0006.0	1
DC Midget Fuse Blocks, and Disconnect	34.136.0002.1	1	34.136.0004.1	1	34.136.0005.1	1	34.136.0006.1	1

Dimensions





PST 40i1

Premium DC Commercial Solar Combiner Boxes





- 8 String
- Commercial combiner box
- High quality components
- NEMA 4 / NEMA 4x enclosure
- 100 A disconnect
- Pre-wired
- Pre-terminated with connectors
- Midget fuse blocks
- Touch safe components
- Clear, simple wiring path
- Grouped and labeled main output

MODEL Type	DCC-C-8-FG 8 String DC Combiner box Fiberglass Enclosure	DCC-C-8 8 String DC Combiner box Painted Steel Enclosure	DCC-C-8-SS 8 String DC Combiner box Stainless Steel Enclosure
Max Voltage	600 VDC	600 VDC	600 VDC
Max Amperage	100 ADC	100 ADC	100 ADC
Approvals			

	Part Number Model Number	Std. Pack	Part Number Model Number	Std. Pack	Part Number Model Number	Std. Pack	Part Number Model Number	Std. Pack
DC Midget Fuse Blocks, and Disconnect	34.256.0008.5 DCC-C-8-FG	1	34.256.0008.0 DCC-C-8	1	34.256.0008.9 DCC-C-8-SS	1		
SPD Midget Fuse Blocks, Disconnect, and SPD	34.256.1008.5 DCC-C-SPD-8-FG	1	34.256.1008.0 DCC-C-SPD-8	1	34.256.1008.9 DCC-C-SPD-8-SS	1		
SPD, SM Midget Fuse Blocks, Disconnect, SPD, and String Monitor	34.256.2008.5 DCC-C-SPD-SM-8-FG	1	34.256.2008.0 DCC-C-SPD-SM-8	1	34.256.2008.9 DCC-C-SPD-SM-8-SS	1		

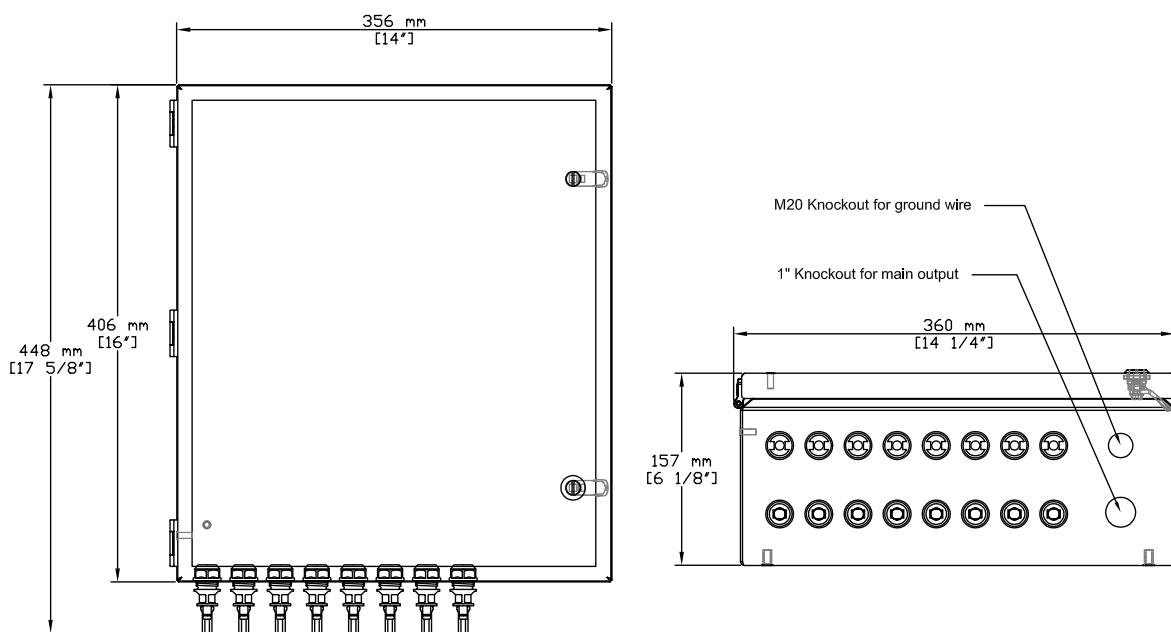
Dimensions



gesis

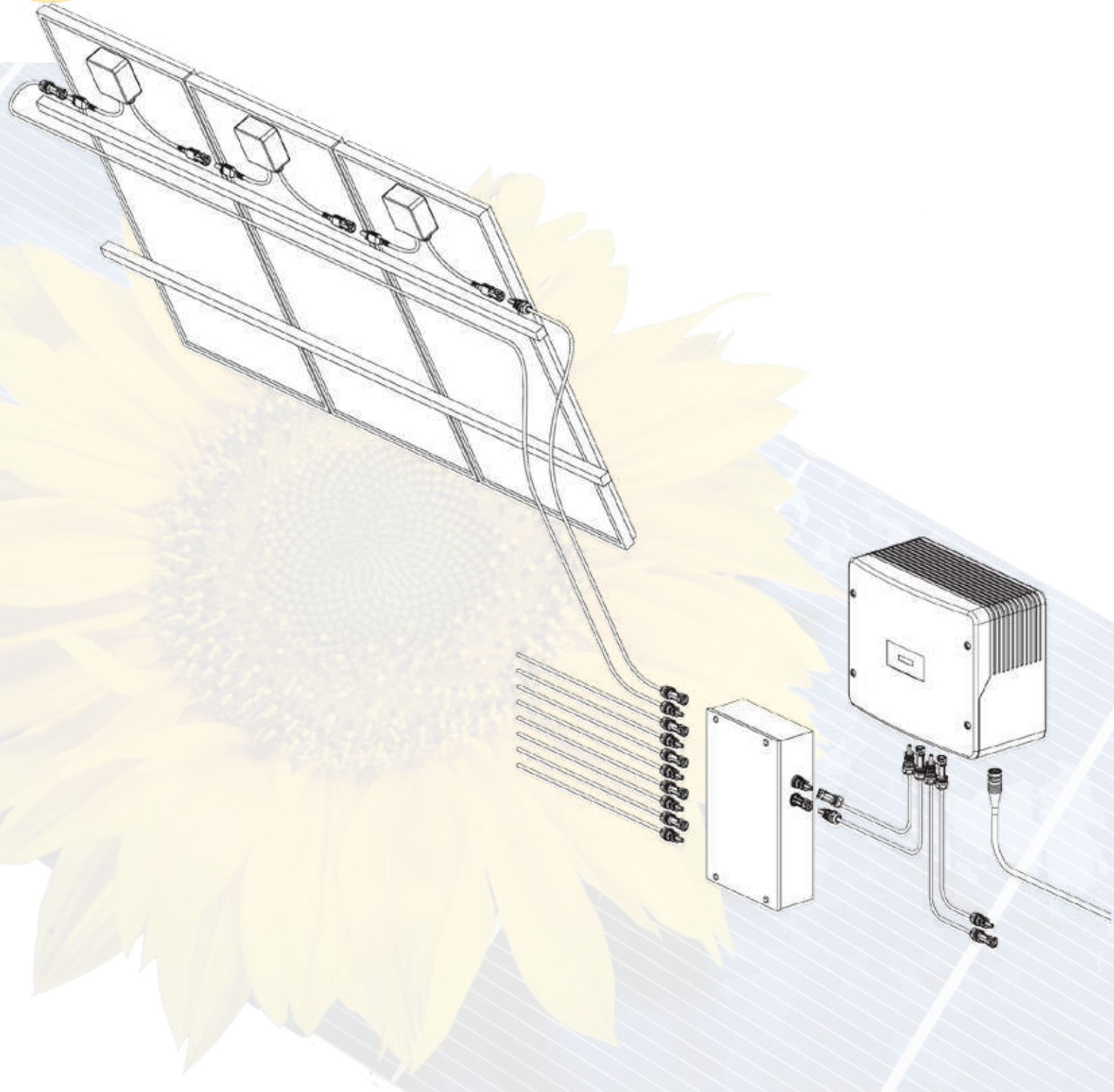

PST 40i1
DC Solar Accessories



		Part Number Model Number	Std. Pack	Part Number Model Number	Std. Pack	Part Number Model Number	Std. Pack	Part Number Model Number	Std. Pack
Crimp Tool Removal Tool, and wire stripper		99.425.0000.0	1						
Crimp Tool Includes Removal Tool		99.615.0000.0	1						
Crimp Tool		99.630.0000.0	1						
Removal Tool		05.502.1400.0							
Disconnect Tool		34.250.0015.0							

Cover Plug For Female Connectors		05.566.6380.0	1						
Cover Plug For Male Connectors		05.566.6480.0	1						
Tethered Cover Plug For Female Connectors		Z5.566.6380.0	1						
Tethered Cover Plug For Male Connectors		Z5.566.6480.0	1						
Locking Clip For Mated Connectors		05.568.2756.0	1						

Screwdriver Flat Head		06.502.4000.0	1						
Wire Stripping tool For PV Cable		34.250.0014.0	1						

Rated voltage:	1000 V (600V UL / CSA)
Pollution degree:	III
Overvoltage category:	3
Application ID:	A
Protection class:	II
Rated current:	17.5 A – 1.5 mm ² (16 AWG) 24.0 A – 2.5 mm ² (14 AWG) 32.0 A – 4.0 mm ² (12 AWG) 40.0 A – 6.0 mm ² (10 AWG) 40.0 A – 10.0 mm ² (8 AWG)
Wire range:	min. 1.5 mm ² ; max. 10.0 mm ² (16 AWG - 8 AWG)
Degree of protection:	IP 65 – IP 68 (mated pair or with cover plug)
Connection technology:	Crimp
Insulation strip length:	13mm (+/- 1mm)
Ambient temperature:	-40° C – +85° C
Tightening torque:	3.5 Nm for cable glands to ensure strain relief and tightness
Approval:	TÜV VDE 0126-3 cETLus UL 486A-486B No.65-03, UL 486D CSA C22.2 No. 198.2-05

Notice: PST connectors must not be disconnected under load!

Features:
Solid (machined) brass contacts, silver-plated
Field assembly version is capable of multiple rewirings
Small number of components comprise entire system and facilitate assembly
Same contacts for field assembly, factory assembly and installation
Can be used throughout the entire temperature range (no restrictions due to derating curve)
Robust design
Mates with industry standard connectors

The solar cables from various manufacturers differ with regard to material, hardness and diameter. Therefore pre-assembly must check the tightness of the cable glands and increase the tightening torque for safety purposes, if required.

In general, the installer is responsible for proper cable and connector assembly

PST 40i1
DC Solar Technical Information



PST40i1
Configuration

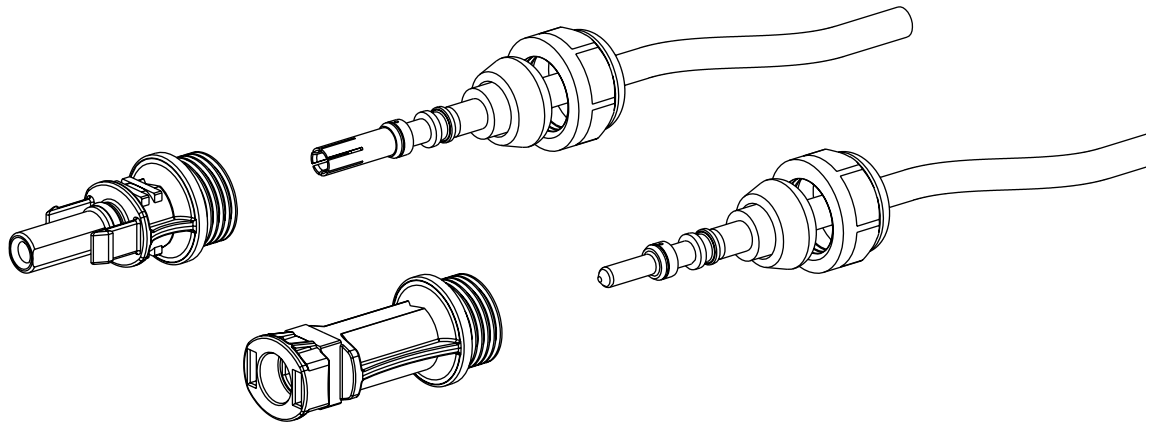

PST40i1
Female
Dimensions

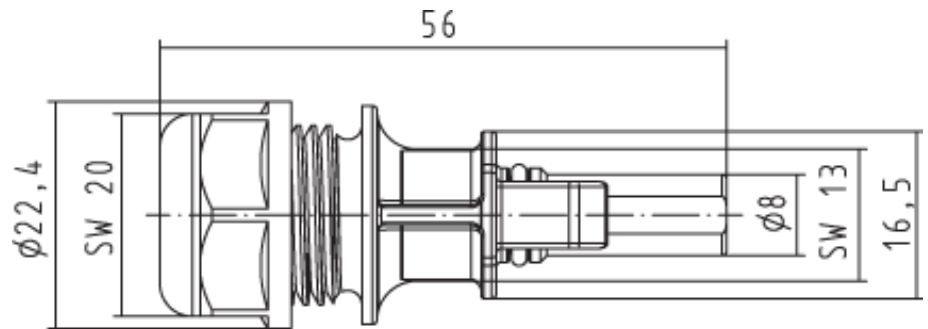

PST40i1
Male
Dimensions

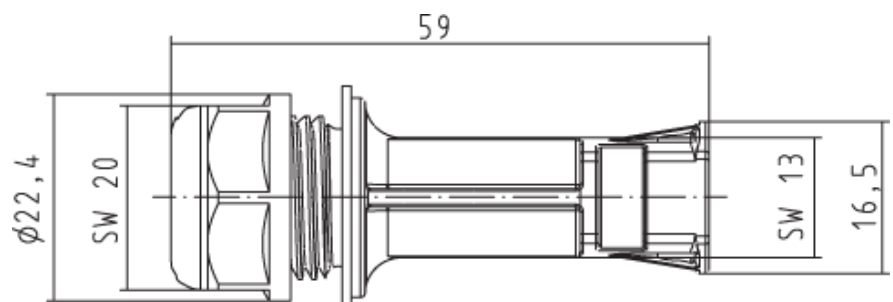

Part Number	Page	Part Number	Page
02.125.8002.8	5	34.253.0025.0	7
02.125.8102.8	5	34.253.0025.1	7
02.125.8202.8	5	34.253.0031.0	7
02.125.8302.8	5	34.253.0031.1	7
02.125.8402.8	5	34.253.0050.0	7
05.502.1400.0	15	34.253.0050.1	7
05.545.2002.8	5	34.253.0100.0	7
05.545.2102.8	5	34.253.0100.1	7
05.545.2202.8	5	34.256.0008.0	13
05.545.2302.8	5	34.256.0008.5	13
05.545.2402.8	5	34.256.0008.9	13
05.566.6380.0	5	34.256.0502.5	10
05.566.6380.0	15	34.256.0505.5	11
05.566.6480.0	15	34.256.1008.0	13
05.568.2756.0	5	34.256.1008.5	13
05.568.2756.0	15	34.256.1008.9	13
06.502.4000.0	15	34.256.2008.0	13
34.136.0002.0	12	34.256.2008.5	13
34.136.0002.1	12	34.256.2008.9	13
34.136.0004.0	12	99.425.0000.0	15
34.136.0004.1	12	99.615.0000.0	15
34.136.0005.0	12	99.630.0000.0	5
34.136.0005.1	12	99.630.0000.0	15
34.136.0006.0	12	Y6.111.0053.1	5
34.136.0006.1	12	Y6.111.0153.1	5
34.250.0014.0	15	Y6.111.0253.1	5
34.250.0015.0	5	Y6.111.1053.1	5
34.250.0015.0	15	Y6.112.0053.1	5
34.253.0001.0	7	Y6.112.0153.1	5
34.253.0001.1	7	Y6.112.0253.1	5
34.253.0002.0	7	Y6.112.1053.1	5
34.253.0002.1	7	Z5.566.6380.0	5
34.253.0005.0	7	Z5.566.6380.0	15
34.253.0005.1	7	Z5.566.6480.0	15
34.253.0010.0	7		
34.253.0010.1	7		





wieland

Wieland Electric Canada
2889 Brighton Road
Oakville, Ontario
Canada
L6H 6C9

1 800-Wieland (943-5263)
Tel. (905) 829-8414
Fax. (905) 829-8413
www.wieland-electric.ca
info@wieland-electric.ca

Industrial technology

Solutions for the control cabinet

- DIN rail terminal blocks
 - Screw, spring clamp or IDC connection technology
 - Wire cross sections up to 240 mm²
 - Numerous special functions
 - Software solutions interfacing to CAE systems
- Safety
 - Safety sensors
 - Safety relays
 - Modular safety systems with fieldbus link
- PLC and fieldbus components
 - Standard applications in IP20
 - Increased environmental conditions with railroad and ship approvals
- Interface
 - Coupling relays, semiconductor switches
 - Measuring and monitoring relays
 - Timer and switching relays
 - Analog modules
 - Passive interfaces
 - Power supply units
 - Overvoltage protection

Solutions for field applications

- Remote automation technology
 - Power distribution
 - Fieldbus interfaces and motor starters
- Connectors for industrial applications
 - Square and round connectors
 - Aluminum or plastic housings
 - Degree of protection up to IP68
 - Current-carrying capacity up to 100 A
 - Connectors for hazardous areas
 - Modular, application specific technology

PC board terminals and connectors

- Screw or spring clamp connection technology
- Spacings: 3.5 mm to 10.16 mm
- Reflow or wave soldering process

Building and installation technology

- Building installation systems
 - Main power supply connectors IP20/IP65... IP68
 - Bus connectors
 - Combined connectors
 - Low-voltage connectors
 - Power distribution system with flat cables
 - Distribution systems
 - Bus systems in KNX, LON and radio technology
 - DIN rail terminal blocks for electrical installations
 - Overvoltage protection

34.205.0162.4 11/10

**contacts
are
green.**

Product Range