

**ADTS6, ADTSM &
AKTSC6 SERIES
(SQUARE STEM WITH CAP OPTIONS)
MECHANICAL CONTACT STYLE**

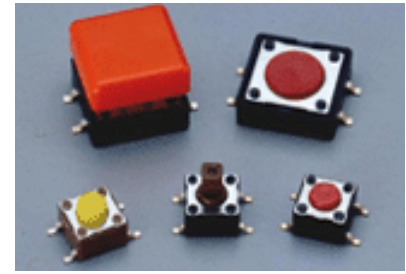

FEATURES

- Positive tactile feedback.
- Ultraminiature structure suitable for high density mounting. Economic but high reliability.
- Insert molded terminals prevent flux build-up during soldering.

MATERIALS

COVER:	Stainless steel.
BASE:	UL94V-0 Nylon Thermoplastic. Color: Black
STEM:	UL94V-0 Nylon Thermoplastic. Color: Black(100gf), Brown(160gf), Red(260gf), Salmon(320gf), Yellow(520gf) Silicone rubber Color: Red(300gf)
CONTACT DISC:	Phosphor bronze with silver cladding.
TERMINAL:	Brass with silver plating.
CAP:	Termoplastic ABS.

GENERAL SPECIFICATIONS

ELECTRICALS

Electrical life:	100,000 cycles for 320gf, 520gf. 100,000 cycles for 260gf. 200,000 cycles for 100gf, 160gf.
Rating:	50 mA, 12 VDC.
Contact resistance:	100 milliohms max.
Insulation resistance:	100 megohms min. 500 VDC.
Dielectric Strength:	250 VAC /1 minute.
Contact Arrangement:	1 pole 1 throw.

MECHANICALS

Operational Force:	520 ± 130gf Brown (Y) 320 ± 80gf Brown (S) 260 ± 50gf Red (R) 160 ± 50gf Brown (N) 100 ± 50gf Black (K)
Stop Strength:	Max 3kgf vertical static load continuously for 15 seconds.
Stoke:	(12x12) 0.35 ± 0.1 mm (6x6) 0.25 ± 0.2 mm - 0.1 mm
Operating Temperature Range:	-25°C to + 70°C
Storage Temperature Range:	-30°C to + 80°C
Vibration resistance:	MIL-STD-202F METHOD 201A. Frequency: 10-55-10Hz/1 minute. Directions: X,Y,Z, three mutually perpendicular directions. Time: 2 hours each direction. High reliability.
Shock resistance:	MIL-STD-202F METHOD 213B. Frequency: 10-55-10Hz/1 minute. Directions: X,Y,Z, three mutually perpendicular directions. Time: 2 hours each direction. High reliability.

SPECIFICATIONS SUBJECT TO CHANGE WITHOUT NOTICE.

SOLDERING PROCESSES

WAVE SOLDERING: Recommended solder temperature at 500°F (260°C) max. 5 seconds subject to PCB 1.6mm thickness. (For through hole type)

HAND SOLDERING: Use a soldering iron of 30 watts, controlled at 350°C approximately 5 seconds while applying solder.

CIRCUIT

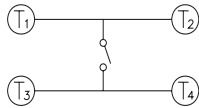

HOW TO ORDER

ADTS



Package Style:

= Bulk Pack

* B = Tube

* Except ADTS-63, 644, 648, 65, 66

Soldering:

V = Lead Free

Color Of Stem For Operating Force:

K= Black, 100gf

N = Brown, 160gf

R = Red, 260gf

S = Salmon, 320gf

Y = Yellow, 520gf

N/K = Black, 160gf

< 12 x 12, K, Y Unavailable >

Dimension H:

6 x 6mm:

1 = 4.3mm

2 = 5.0mm

3 = 7.0mm

44= 7.3mm (SQ.) x 2.4mm

48= 7.3mm (SQ.) x 2.8mm

5 = 9.5mm

6 = 13mm

12 x 12mm:

1 = 4.3mm

4 = 7.3mm (SQ.) x 3.8mm

5 = 8.5mm

Prod. Size

6 = 6.6mm

2 = 12 x 12mm

= None Post

M = Surface Mount

SPECIFICATIONS SUBJECT TO CHANGE WITHOUT NOTICE.

ADTS6V**

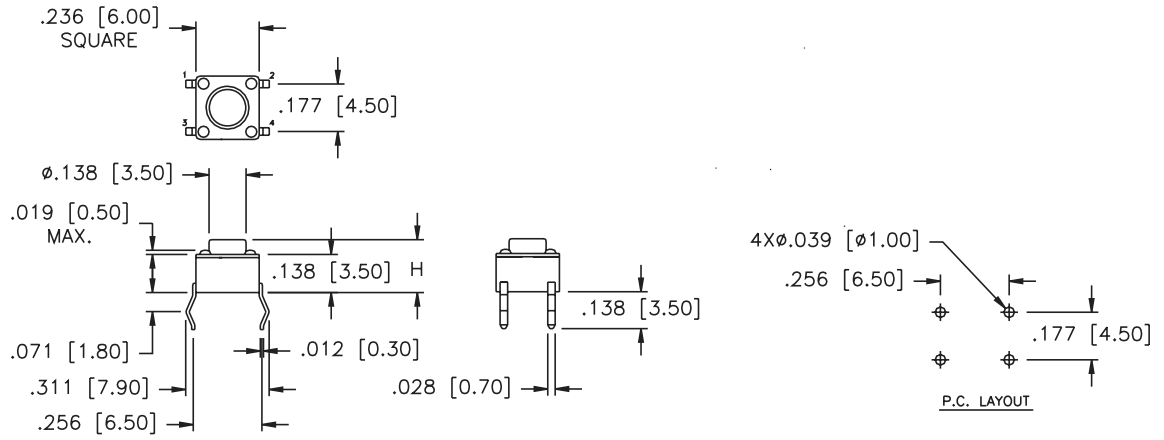

ADTS64V**

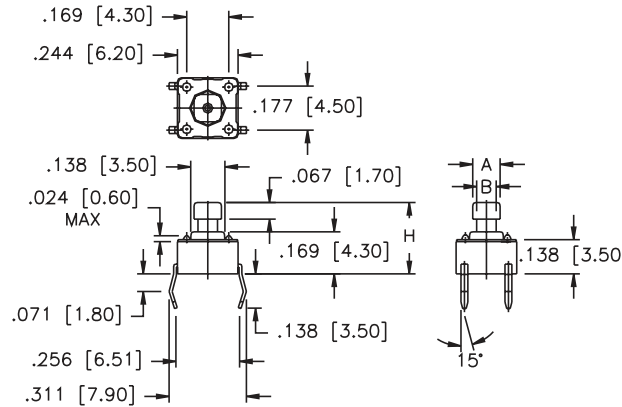

PRODUCT NO.	LOC.	MM.	INCH
ADTS644*V	A	2.4	[.095]
	B	1.6	[.063]
ADTS648*V	A	2.8	[.110]
	B	2.0	[.079]

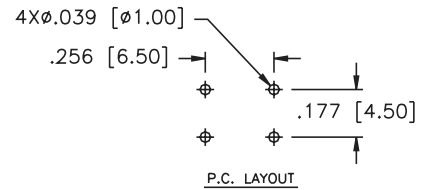

ADTS2V**

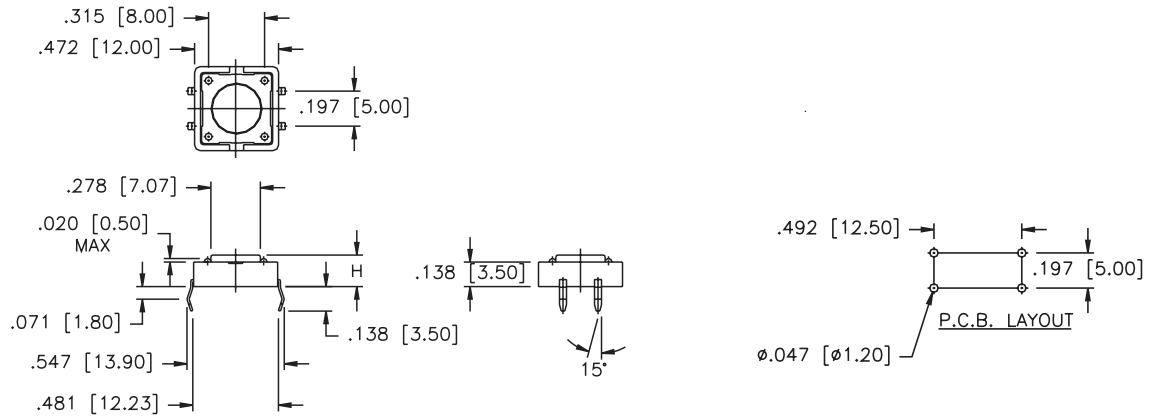
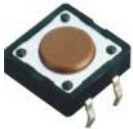

ADTS24*V

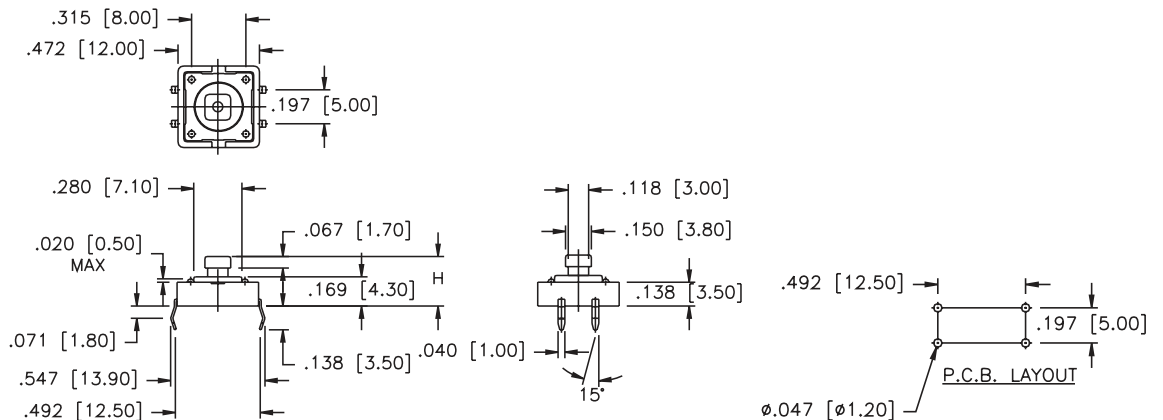

ADTSM6V**

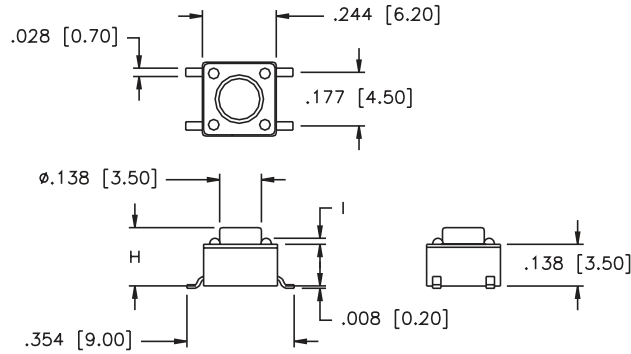

PART NUMBER.	DIM. I
ADTSM62-66*	.024 MAX.
ADTSM61*	.020 MAX.

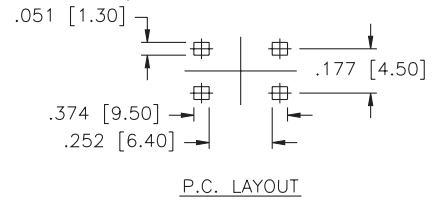

P.C. LAYOUT

ADTSM64V**

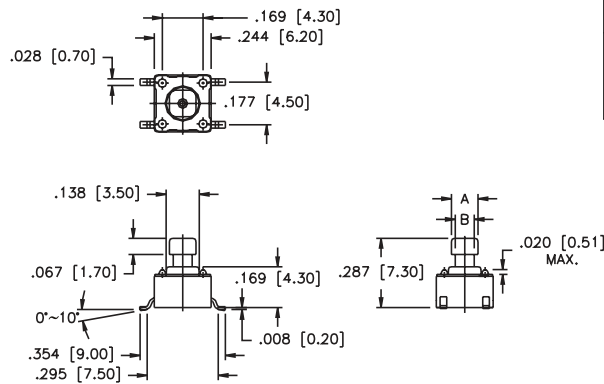

PART NUMBER.	DIM. A	DIM. B
ADTSM644*V*	.094 [2.4]	.063 [1.6]
ADTSM648*V*	.100 [2.8]	.079 [2.0]

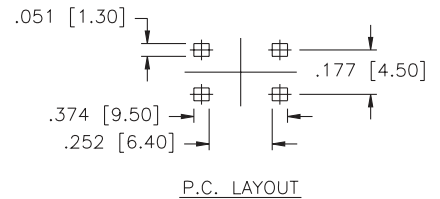

P.C. LAYOUT

ADTSM2V**

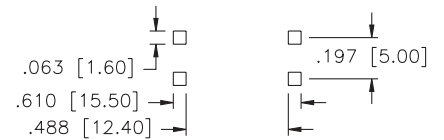
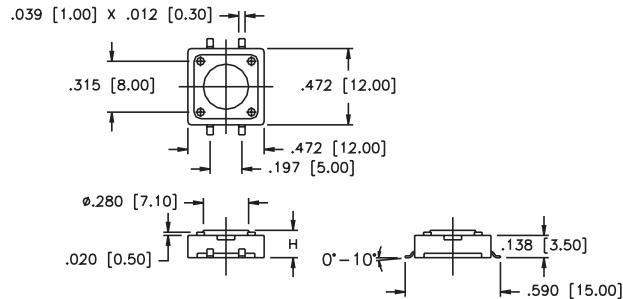

P.C. LAYOUT

ADTSM24*V

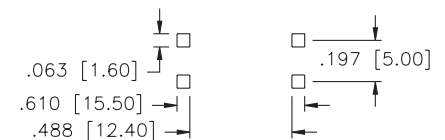
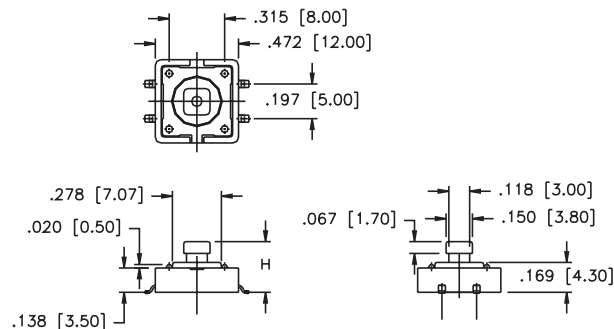

P.C. LAYOUT

SPECIFICATIONS SUBJECT TO CHANGE WITHOUT NOTICE.

AKTSC CAPS



CAP PART NO.

AKTSC

Cap Type:
1 = Square
2 = Round

Prod. Size: (Tactile Switch)
6 = 6 x 6mm
2 = 12 x 12mm

Cap Color:
Y= Yellow
B = Blue
R = Red
I = Ivory
K = Black
G = Green
S = Salmon

SPECIFICATIONS SUBJECT TO CHANGE WITHOUT NOTICE.

AKTSC61

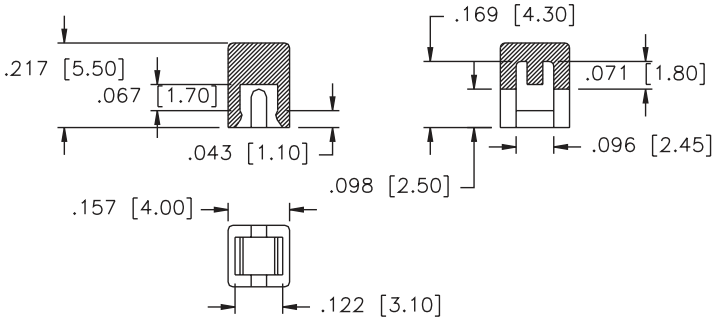

AKTSC62

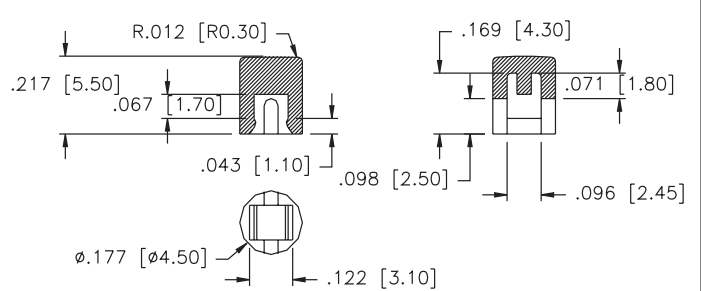

AKTSC21

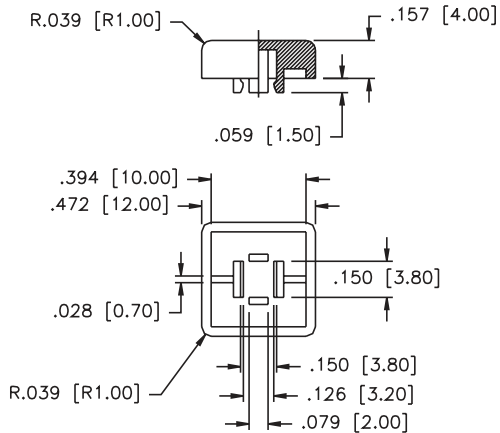

AKTSC22

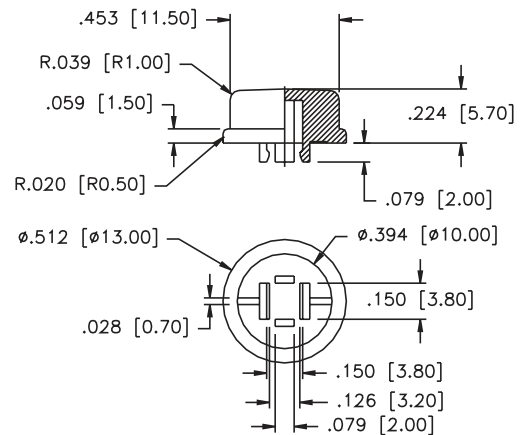

PACKAGING

ADTS-6 Series: 1000 pcs/bag
ADTS(P)-2 series: 500 pcs/bag or 40pcs/tube