

FEATURES

- Wide range of supply voltages
- Low supply current drain independent of supply voltage
- Low input biasing current
- Low input offset current
- Low input offset voltage
- Input common-mode voltage range includes ground
- Differential input voltage range equal to the power supply voltage
- Low output saturation voltage
- Output voltage compatible with TTL, MOS and CMOS logic

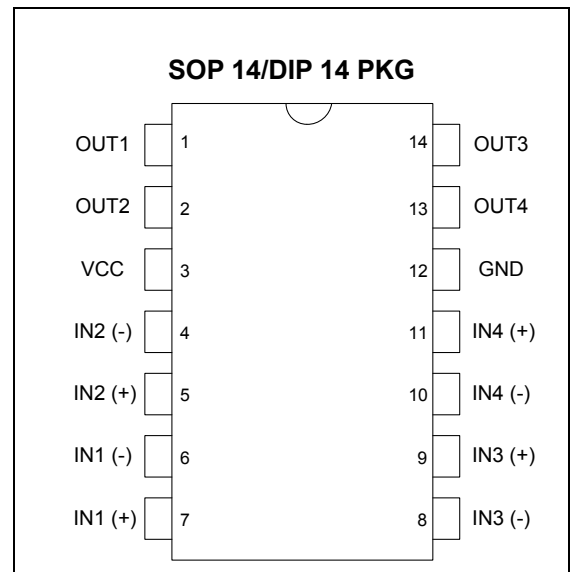

ORDERING INFORMATION

Device	Package
LM339GD	SOP 14
LM339N	DIP 14

DESCRIPTION

The LM339 consists of four independent voltage comparators. These were designed specifically to operate from a single power supply over a wide range of voltages. Operation from split power supplies is also possible and the low power supply current drain is independent of the magnitude of the power supply voltage. The outputs can be connected to other open-collector outputs to achieve wired-AND relationships.

ABSOLUTE MAXIMUM RATING

CHARACTERISTIC	SYMBOL	Value	UNIT
Supply Voltage	V_{CC}	40	V
Input Voltage	V_{IN}	-0.3 to 40	V
Operating Temperature Range	T_{OPR}	-40 to +85	°C

ELECTRICAL CHARACTERISTICS

At specified free-air temperature, $V_{CC}=5V$ (unless otherwise noted)

PARAMETER	TEST CONDITIONS*		MIN	TYP	MAX	UNIT	
V_{IO} Input offset voltage	$V_{CC}=5V$ to $30V$ $V_{IC}=V_{ICR}$ min, $V_O=1.4V$	25 °C		2	5	mV	
		Full temperature range			9		
I_{IO} Input offset current	$V_O=1.4V$	25 °C		5	50	nA	
		Full temperature range			150		
I_{IB} Input bias current	$V_O=1.4V$	25 °C		-25	-250	nA	
		Full temperature range			-400		
V_{ICR} Common-mode input voltage range**		25 °C	0 to $V_{CC}-1.5$			V	
		Full temperature range	0 to $V_{CC}-2$				
A_{VD} Large-signal differential voltage amplification	$V_{CC}=15V$ $V_O=1.4V$ to $11.4V$ $R_L \geq 15k\Omega$ to V_{CC}	25 °C	50	200		V/mV	
I_{OH} High-level output current	$V_{CC}=5V, V_{ID}=1V$	25 °C		0.1	50	nA	
	$V_{CC}=30V, V_{ID}=1V$	Full temperature range			1	uA	
I_{OL} Low-level output current	$V_{OL}=1.5V, V_{ID}=-1V$	25 °C	6			mA	
V_{OL} Low-level output voltage	$I_{OL}=4mA, V_{ID}=-1V$	25 °C		150	400	mV	
		Full temperature range			700		
I_{CC} Supply current	$R_L=\infty$	$V_{CC}=5V$	25 °C		0.8	2	mA
		$V_{CC}=30V$	Full temperature range			2.5	

* Operating temperature for the LM339 is - 40 °C to 85 °C, MAX Junction temperature +125 °C. All characteristics are measured with zero common-mode input voltage unless otherwise specified.

** The voltage at either input or common-mode should not be allowed to go negative by more than 0.3V. The upper end of the common-mode voltage range is $V_{CC} - 1.5V$, but either or both inputs can go to 30V without damage.

SWITCHING CHARACTERISTICS, $V_{CC}=5V, T_A=25^\circ C$

PARAMETER	TEST CONDITIONS*		MI	TY	M	UNIT
Response time	RL connected to 5V through 5.1k, CL=15pF* (See Note 1)	100mV input step with 5-mA overdrive		1.3		us
		Full range		0.3		

NOTE 1: The response time specified is the interval between the input step function and the instant, when the output crosses 1.4V.

TYPICAL PERFORMANCE CHARACTERISTICS

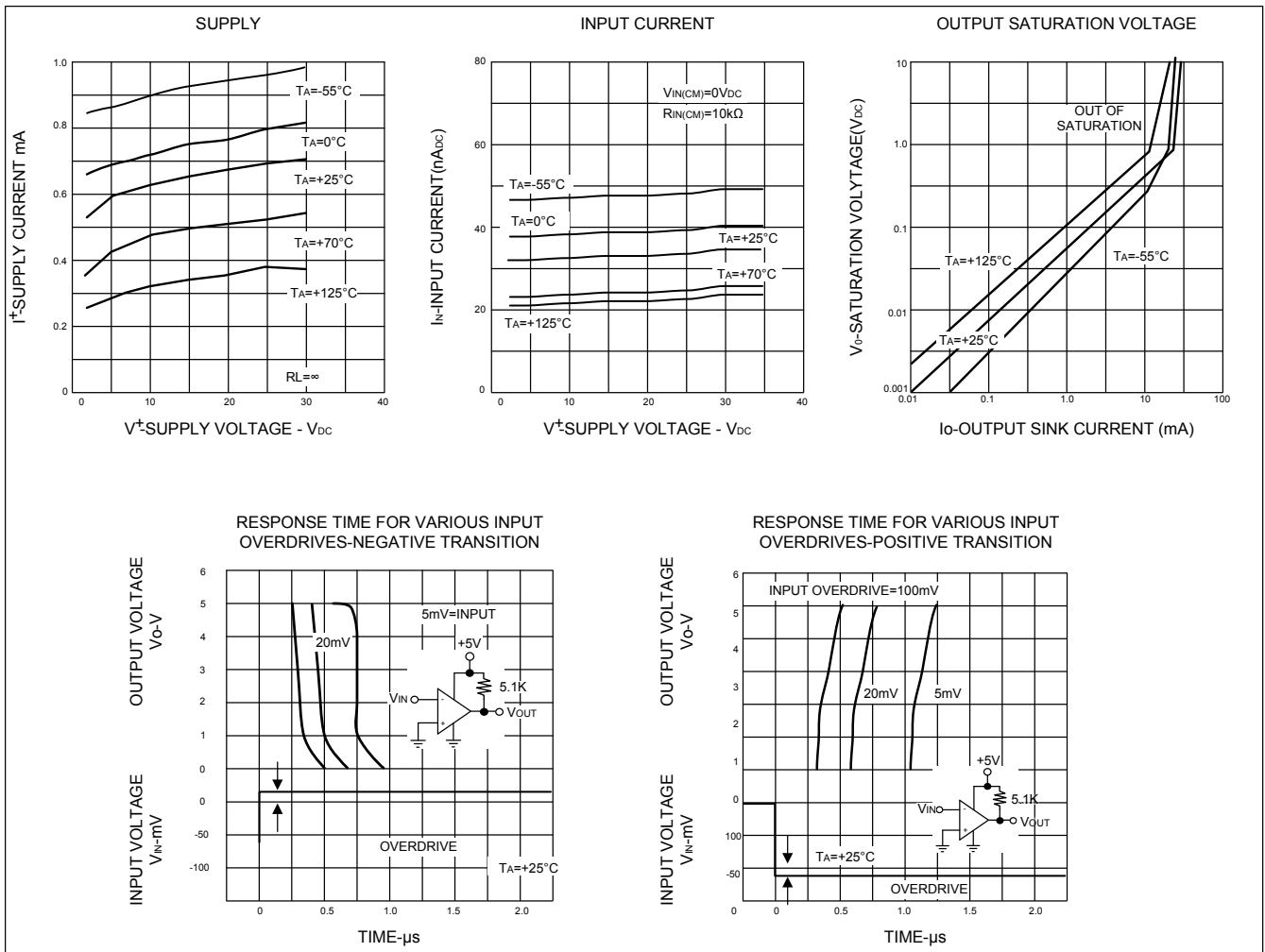

TYPICAL APPLICATIONS

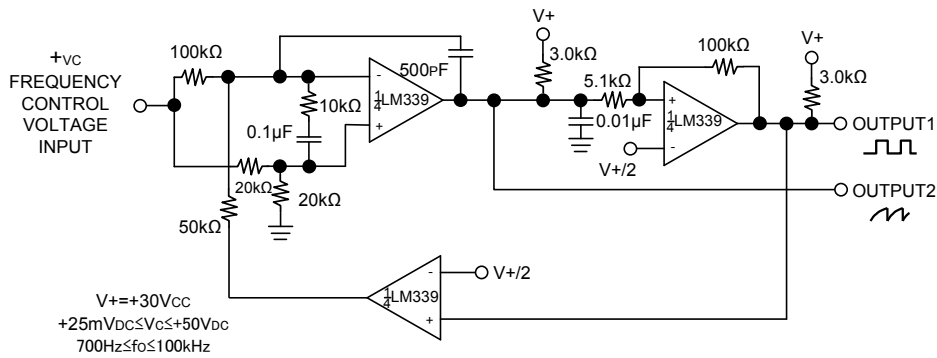

TWO-DECADE HIGH-FREQUENCY VCO

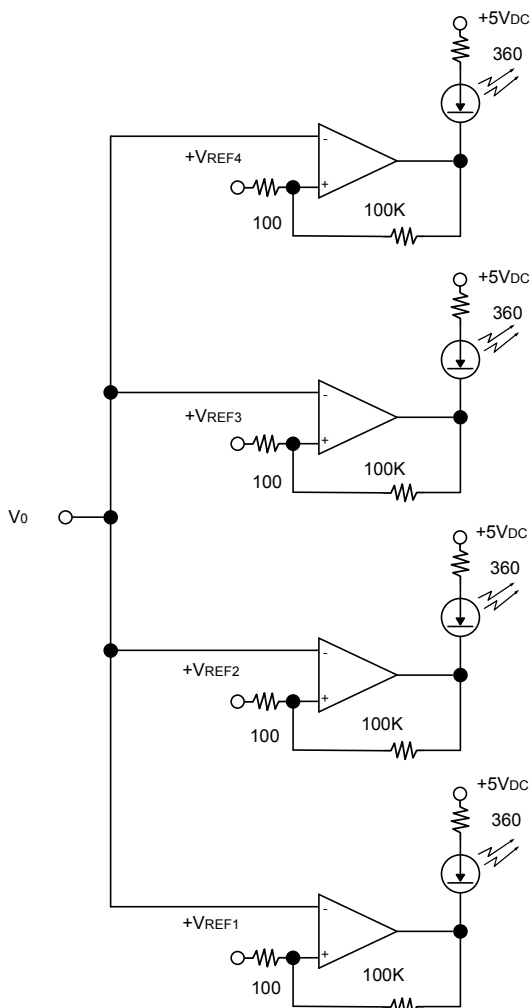

VISIBLE VOLTAGE INDICATOR

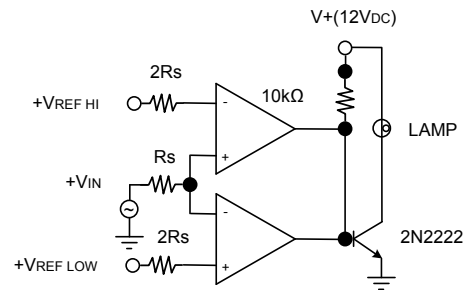

LIMIT COMPARATOR

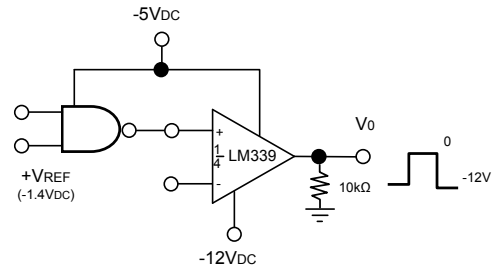

TTL-to-MOS LOGIC CONVERTER

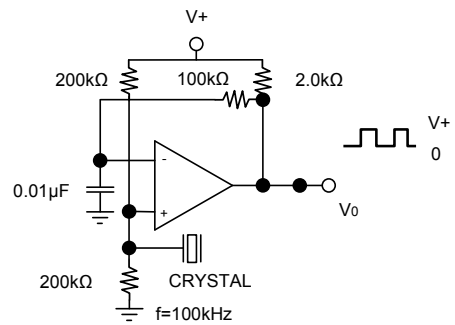

CRYSTAL-CONTROLLED OSCILLATOR