

## FEATURES

- Output Switch Current In Excess of 1.5A
- 2% Reference Accuracy
- Low Quiescent Current : 2.5mA(Typ.)
- Operating From 3V to 40V
- Frequency Operation to 100KHz
- Active Current Limiting
- MC34063AG is Halogen Free Products

## APPLICATION

- Battery Chargers
- NICs / Switches / Hubs
- ADSL Modems
- Negative Voltage Power Supplies

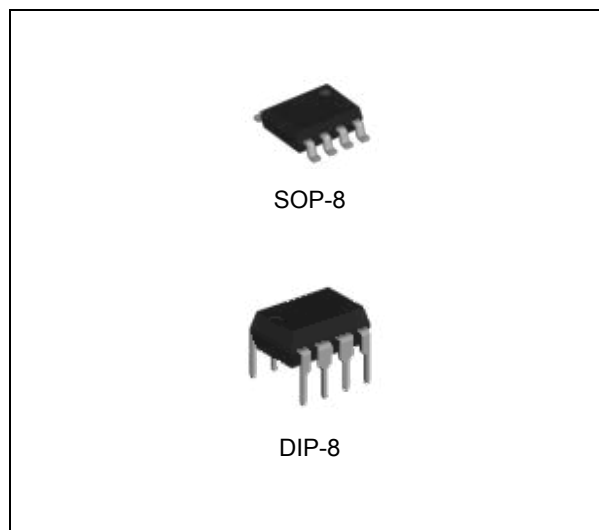

## ORDERING INFORMATION

Device	Package
MC34063AGD	SOP-8
MC34063AGN	DIP-8

## DESCRIPTION

The MC34063AG series is a monolithic control circuit delivering the main functions for DC-DC voltage converting. The device contains an internal temperature compensated reference, comparator, duty cycle controlled oscillator with an active current limit circuit driver and high current output switch.

Output voltage is adjustable through two external resistors with a 2% reference accuracy.

Employing a minimum number of external components the MC34063AG devices series is designed for Step-Down, Step-Up and Voltage-Inverting applications.

## ABSOLUTE MAXIMUM RATINGS (Note 1)

CHARACTERISTIC	SYMBOL	MIN.	MAX.	UNIT
Power Supply Voltage	$V_{CC}$	-	40	V
Comparator Input Voltage Range	$V_{IR}$	-0.3	40	V
Switch Collector Voltage	$V_{SWC}$		40	V
Switch Emitter Voltage( $V_{SWC}=40V$ )	$V_{SWE}$		40	V
Switch Collector to Emitter Voltage	$V_{CE}$		40	V
Driver Collector Voltage	$V_{dc}$	-	40	V
Driver Collector Current <small>(Note 2)</small>	$I_{dc}$	-	100	mA
Switch Current	$I_{SW}$	-	1.5	A

**ABSOLUTE MAXIMUM RATINGS** (Continued)

CHARACTERISTIC	SYMBOL	MIN.	MAX.	UNIT
Junction Temperature Range	$T_J$	-40	150	°C
Storage Temperature Range	$T_{STG}$	-65	150	°C

Note 1. Absolute Maximum Ratings are those values beyond which damage to the device may occur. Functional operation under these conditions is not implied.

(\*) This value depends from thermal design of PCB on which the device is mounted.

**RECOMMENDED OPERATING CONDITIONS**

CHARACTERISTIC	SYMBOL	MIN.	MAX.	UNIT
Supply Voltage	$V_{CC}$	3	40	V
Operating Junction Temperature	$T_J$	-40	125	°C
Operating Ambient Temperature	$T_A$	-40	125	°C

**ORDERING INFORMATION**

Package	Order No.	Description	Supplied As	Status
SOP-8	MC34063AGD	1.5A, 100kHz	Tape & Reel	Active
DIP-8	MC34063AGN	1.5A, 100kHz	Tube	Active

## PIN CONFIGURATION

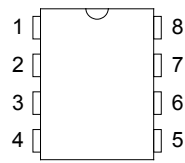

SOP-8 / DIP-8

## PIN DESCRIPTION

Pin No.	DIP-8 PKG	
	Name	Function
1	Switch Collector	Internal switch transistor collector
2	Switch Emitter	Internal switch transistor emitter
3	Timing Capacitor	Timing Capacitor to control the switching frequency
4	GND	Ground pin for all internal circuits
5	Comparator Inverting Input	Inverting input pin for internal comparator
6	V <sub>CC</sub>	Voltage supply
7	I <sub>PK</sub> Sense	Peak Current Sense Input by monitoring the voltage drop across an external I sense resistor to limit the peak current through the switch
8	Driver Collector	Voltage driver collector

## BLOCK DIAGRAM

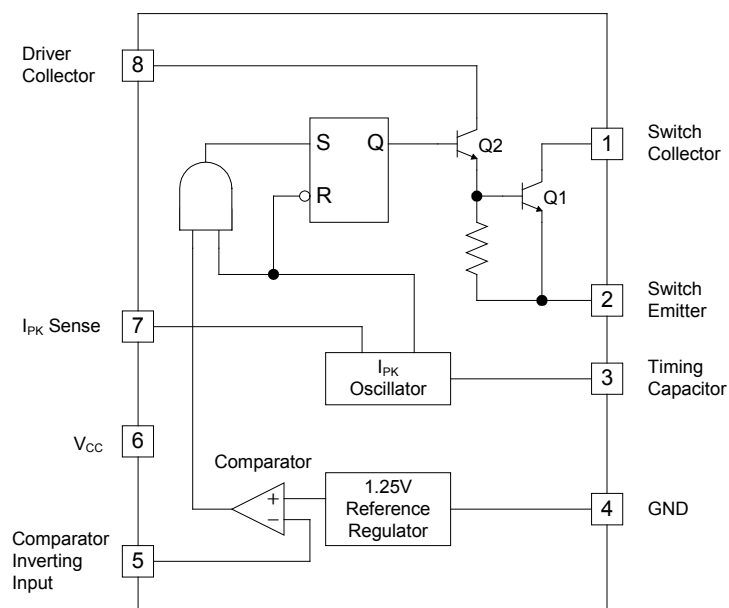

## ELECTRICAL CHARACTERISTICS

(Refer to the test circuits,  $V_{CC}=5V$ ,  $T_A=T_{LOW}$  to  $T_{HIGH}$ , unless otherwise specified, see note 2)

SYMBOL	PARAMETER	TEST CONDITIONS	MIN.	TYP.	MAX.	UNIT
OSCILLATOR						
$F_{OSC}$	Frequency	$V_{PIN5}=0V$ , $C_T=1nF$ , $T_A=25^\circ C$	24	33	42	KHz
$I_{CHG}$	Charge Current	$V_{CC}=5$ to $40V$ , $T_A=25^\circ C$	24	35	42	$\mu A$
$I_{DISCHG}$	Discharge Current	$V_{CC}=5$ to $40V$ , $T_A=25^\circ C$	140	220	260	$\mu A$
$I_{DISCHG}/I_{CHG}$	Discharge to Charge Current Ratio	Pin 7 = $V_{CC}$ , $T_A=25^\circ C$	5.2	6.5	7.5	
$V_{IPK(SENSE)}$	Current Limit Sense Voltage	$I_{CHG}=I_{DISCHG}$ , $T_A=25^\circ C$	250	300	350	mV
OUTPUT SWITCH						
$V_{CE(SAT)}$	Saturation Voltage, Darlington connection	$I_{SW}=1A$ , Pins 1,8 connected		1.0	1.3	V
$V_{CE(SAT)}$	Saturation Voltage	$I_{SW}=1A$ , $R_{PIN8}=82\Omega$ to $V_{CC}$ , Forced $\beta \sim 20$		0.45	0.7	V
$h_{FE}$	DC Current Gain	$I_{SW}=1A$ , $V_{CE}=5V$ , $T_A=25^\circ C$	50	75		
$I_{C(OFF)}$	Collector Off-State Current	$V_{CE}=40V$		1.0	100	$\mu A$
COMPARATOR						
$V_{TH}$	Threshold Voltage	$T_A=25^\circ C$	1.225	1.25	1.275	V
		$T_A=T_{LOW}$ to $T_{HIGH}$	1.21		1.29	V
$REG_{LINE}$	Threshold Voltage Line Regulation	$V_{CC}=3$ to $40V$		1.4	5	mV
$I_{IB}$	Input Bias Current	$V_{IN}=0V$		-20	-400	nA
TOTAL DEVICE						
$I_{CC}$	Supply Current	$V_{CC}=5$ to $40V$ , $C_T=1nF$ Pin7 = $V_{CC}$ , $V_{PIN5}>V_{TH}$ , Pin2=GND Remaining pins open		1.4	4	mA

Note 1. Maximum package power dissipation limit must be observed.

Note 2.  $T_{LOW} = -40^\circ C$ ,  $T_{HIGH} = +125^\circ C$ 

Note 3. If Darlington configuration is not used, care must be taken to avoid deep saturation of output switch.

The resulting switch-off time may be adversely affected.

In a Darlington configuration the following output driver condition is suggested:

$$\text{Forced } \beta \text{ of output switch : } \frac{I_{C(OUTPUT)}}{I_{C(DRIVER)} - 7.0mA^*} \geq 10$$

\* Currentless due to a built in  $1K\Omega$  anti-leakage resistor

TYPICAL ELECTRICAL CHARACTERISTICS

Emitter Follower Configuration Output Saturation Voltage vs. Emitter Current

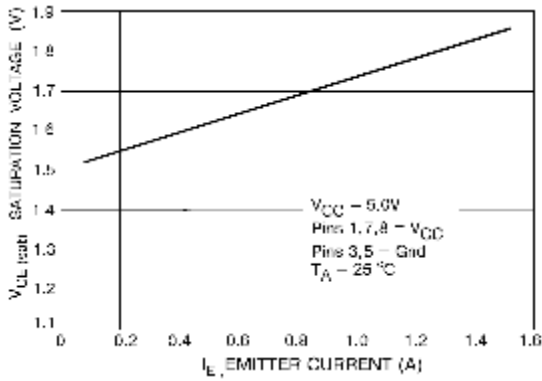

Output Switch ON-OFF Time vs. Oscillator Timing Capacitor

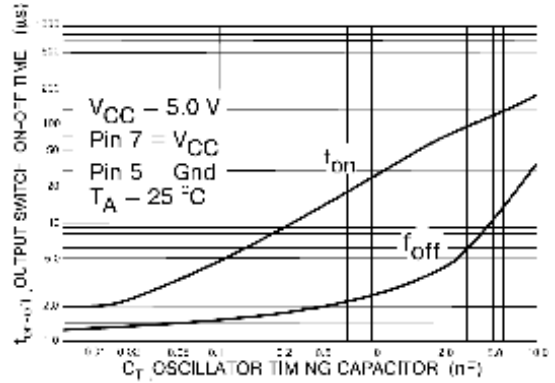

Common Emitter Configuration Output Switch Saturation Voltage vs. Collector Current

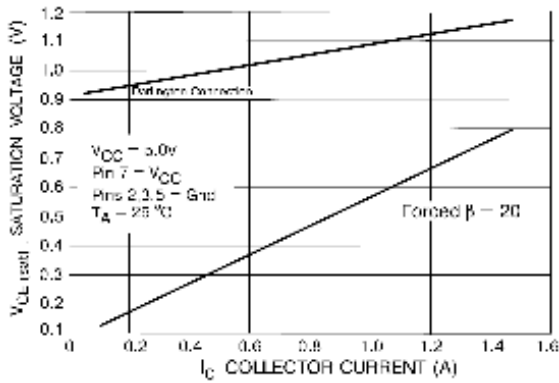

Current Limit Sense Voltage ( $V_{IPK}$ ) vs. Temperature

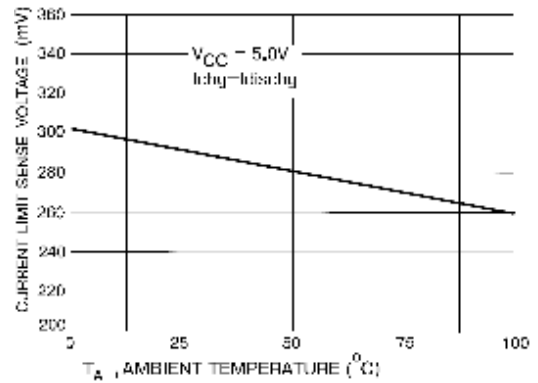

Standby supply current vs. Supply voltage

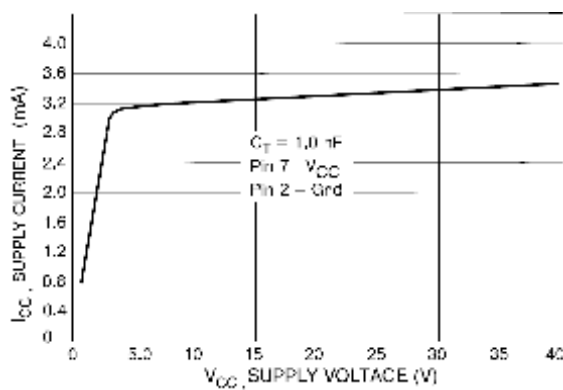

## TYPICAL APPLICATION CIRCUIT

### Step-Up Converter

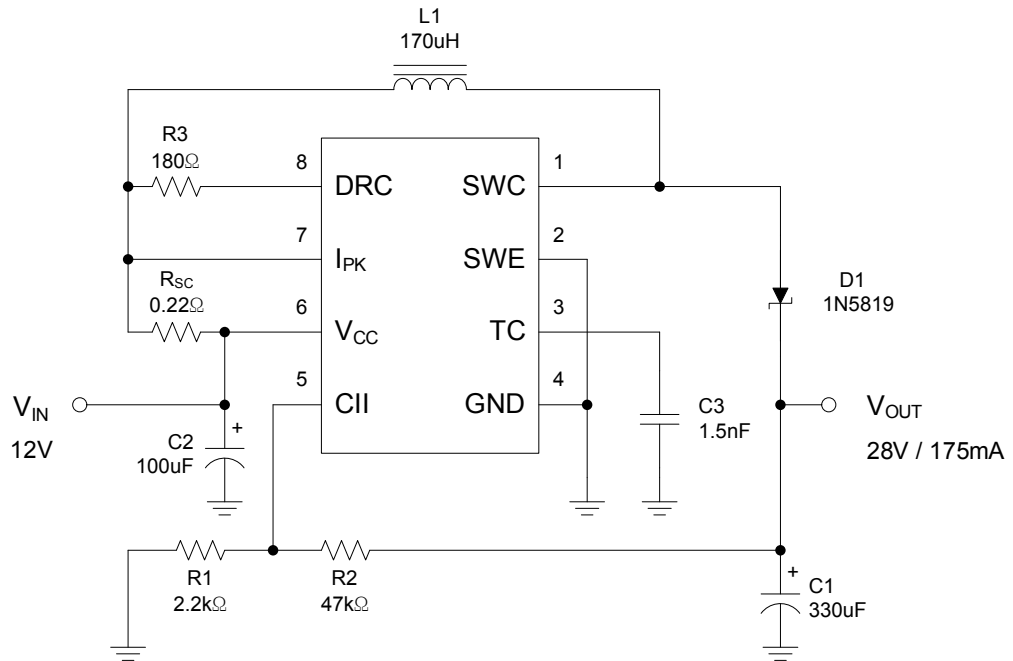

### Step-Down Converter

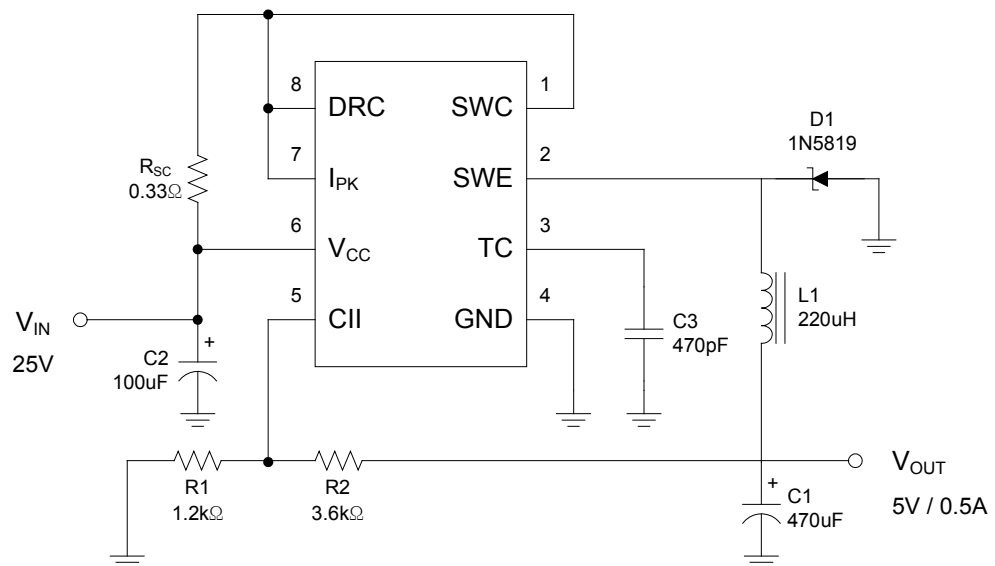

## Step-Up with External NPN Switch

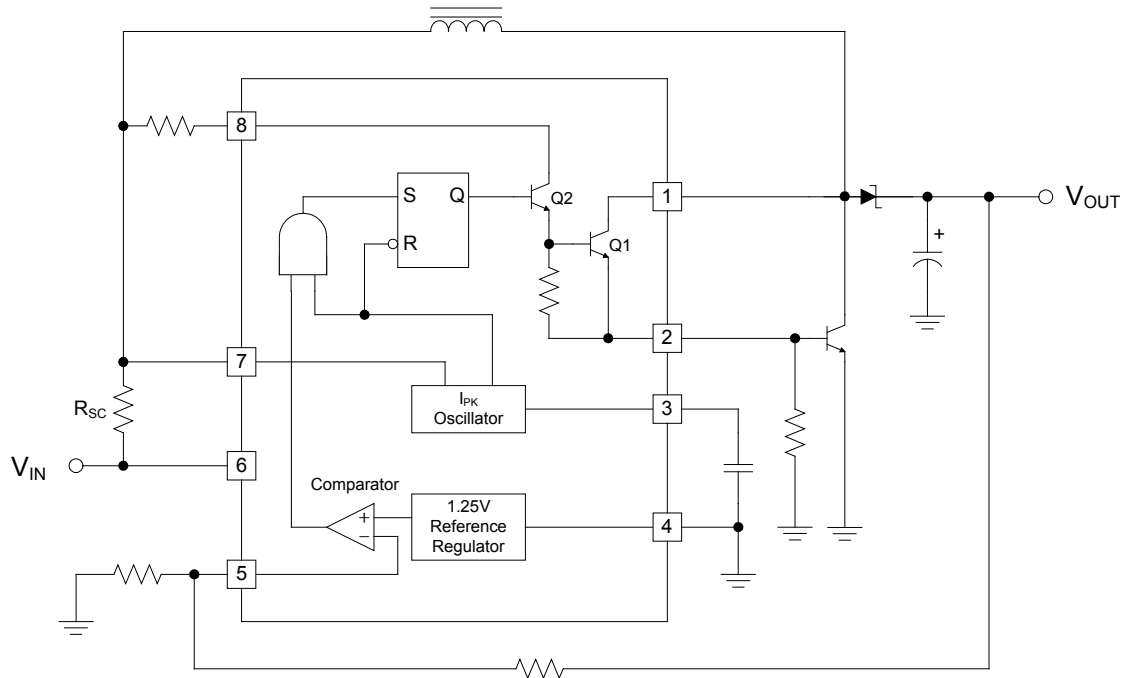

## Voltage Inverting Converter

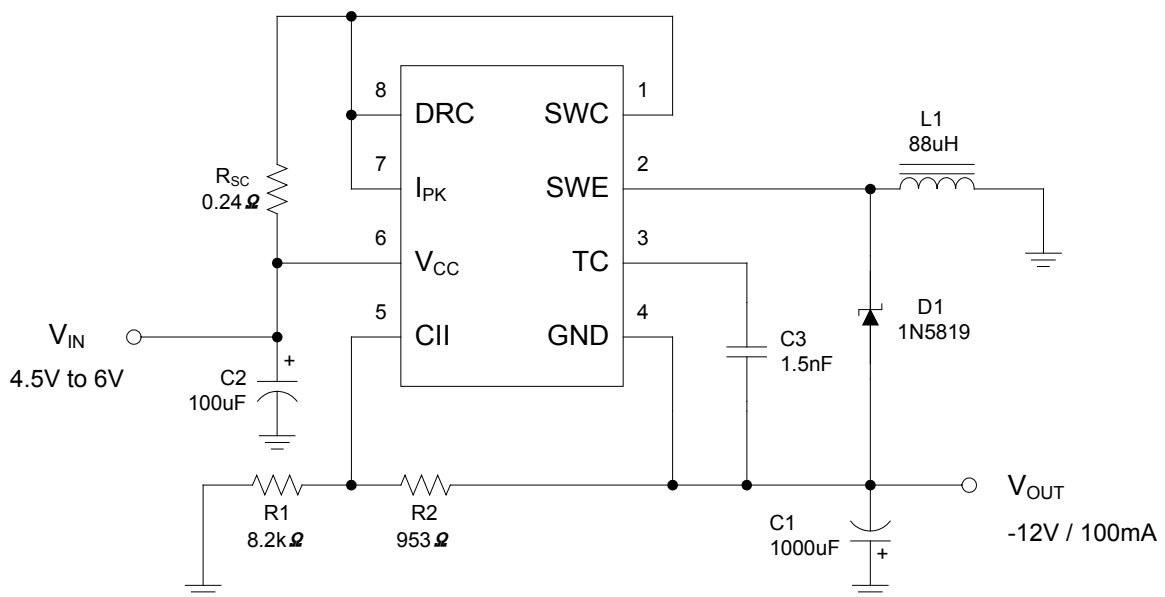

Step-Down with External PNP Switch

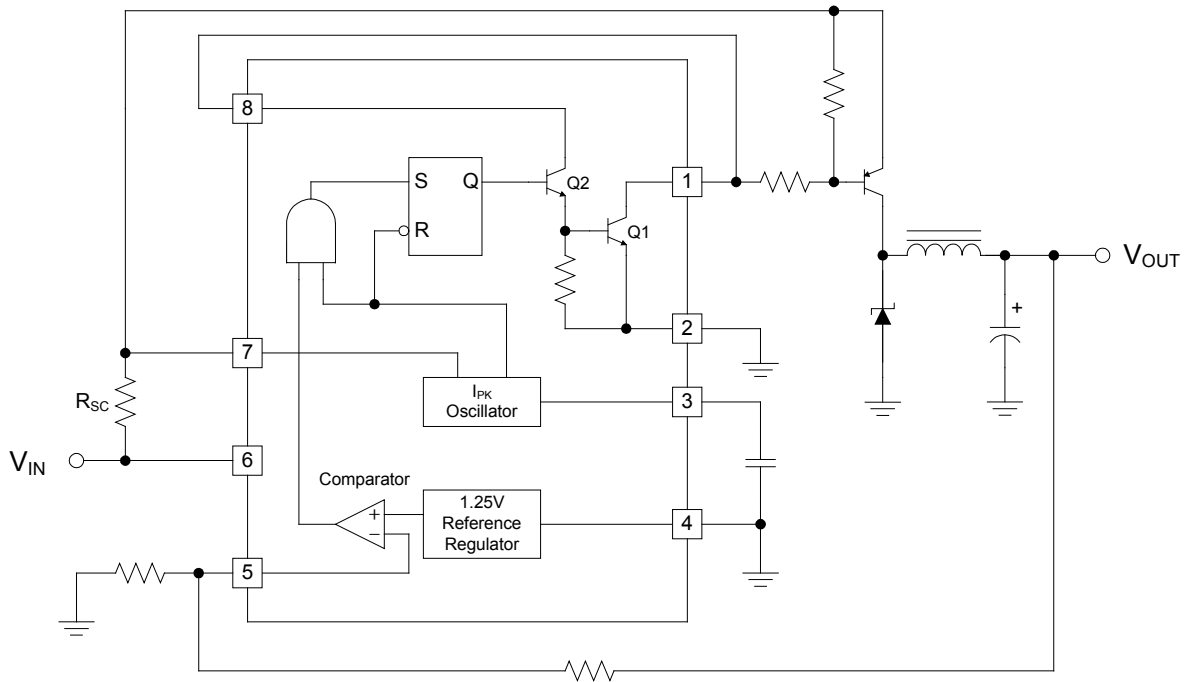

Voltage Inverting with External NPN Switch

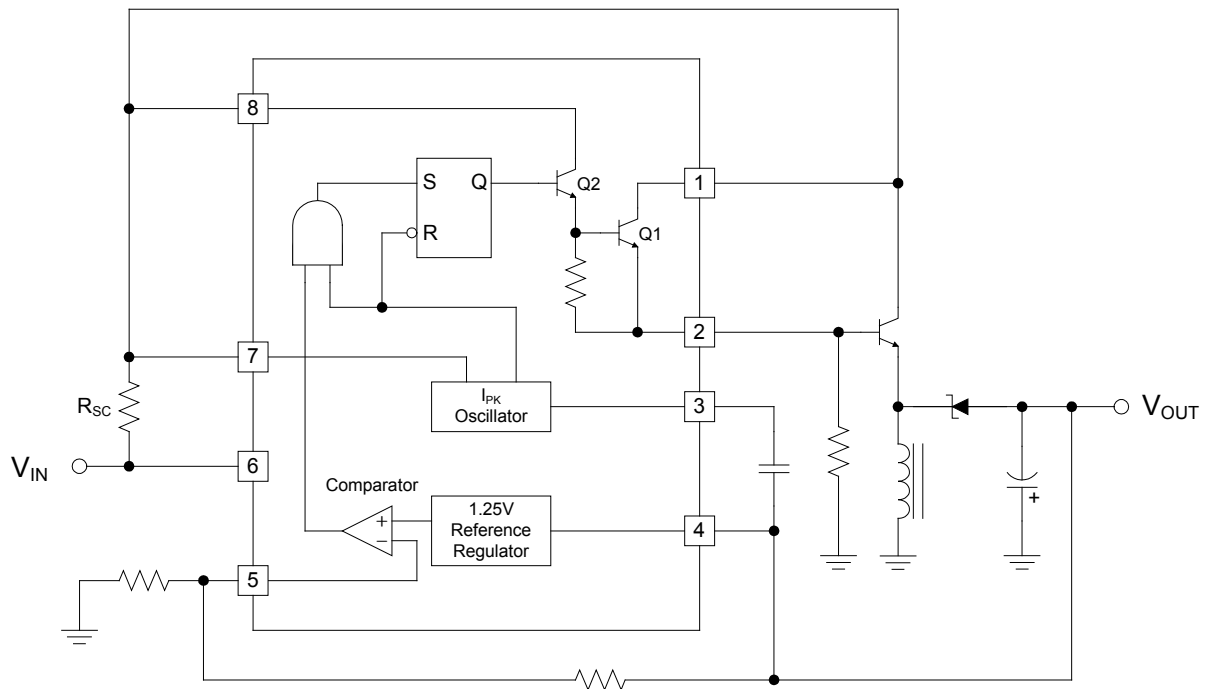



### REVISION NOTICE

The description in this datasheet can be revised without any notice to describe its electrical characteristic properly.