



Side-by-Side C-Leg Station



Supply Cart

The C-Leg Series is the foundation of Production Basics' modular, ergonomic workstations. The rigid back frame is constructed of heavy gauge steel tubing and unistrut channel.

Accessories attach to the channel using the Basic Nut and Basic Bolt. This allows for micro-adjustment of your accessories to the most comfortable position.

Create cells and unique configurations using our station kits or separate components. Our modular double-sided frames and shared legs bring you closer to an ergonomically sound facility that is ready to grow as your business grows.

C-Leg Series



DIVERSE
ELECTRONICS

1-800-381-7308 514-388-7308

www.diverseelectronics.com

sales@diverseelectronics.com

General Information - C-Leg Series

- Stock color on all C-Leg Stations is Blue with White standard laminate or Grey ESD laminate.
- Other frame colors available upon request at no additional charge are Almond, White, Grey and Black. See inside back cover.
- Other laminate colors available upon request at no additional charge are White, Beige and Grey.
- Station kits include all necessary parts, hardware and instructions needed to assemble and finish the workstation.
- Unless noted, worksurface depth (D) is always specified first in dimension notation. Station width (W) is specified second.
- Standard frame height is 64". For other frame heights, see Component Kits (page 18) or choose components independently.
- Standard height adjustability range is 30-36" in 2" increments. For 36-42" height adjustable legs, choose components independently.
- All metal workstation components are constructed of 11-16 gauge steel.
- Workstation kits noted as "ESD" include ESD laminate and ground bolt.
- Laminate worksurfaces are constructed of 1.25" thick industrial grade particle board. ESD laminate measures within the static dissipative range of 10^6 to 10^9 ohms to ground.
- Choose accessories for your C-Leg Series workstation on pages 55-76.
- Workstations accommodate up to 24" of vertical drawer space. Under-surface accessories and casters may reduce this range.
- Above-surface usable space is 26"-32" depending on worksurface height.
- C-Leg Series workstations are shipped KD (knocked down) and assembly is required unless otherwise ordered by customer.
- C-Leg Series workstation weight capacity is 750 evenly distributed pounds.
- Custom frame colors are available at an additional charge.
- Custom laminate colors are available at an additional charge.
- For options not specified in this section, review the Custom Options section of this Product Specifier (pages 77-83) or contact Production Basics.

NEW

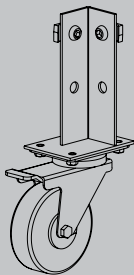

Corner Caster, pg. 17

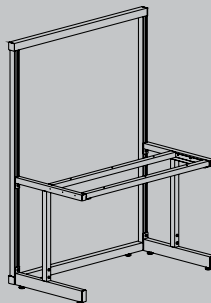

Component Kit, pg. 18

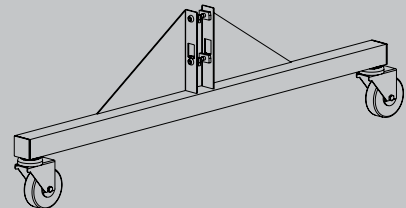

L-Leg with Casters, pg. 20

Typical Configurations - C-Leg Series

We have included a sampling of popular configurations to help you choose the ideal C-Leg Series workstation. For assistance choosing your workstations, call Production Basics at 800.318.2770.

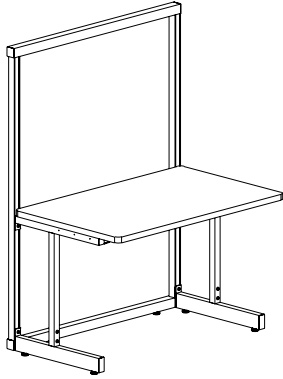

Stand-Alone

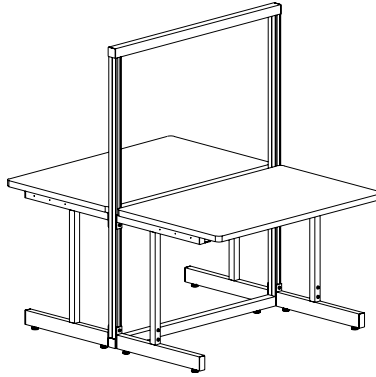

Back-to-Back

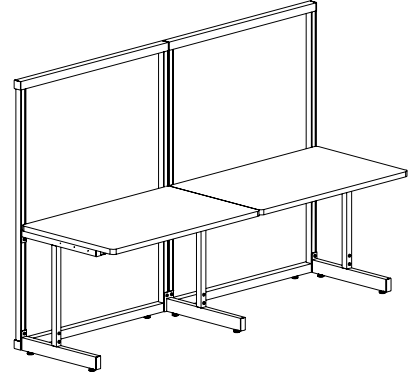

Stand-Alone + Add-on

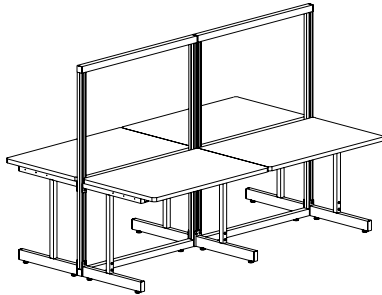

Quad

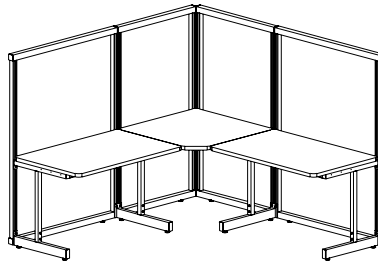

L-Shaped

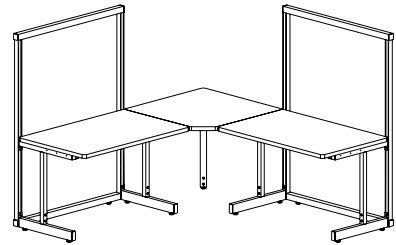

Open Corner

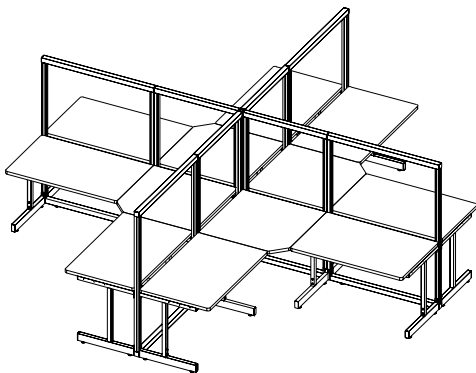

Corner Quad

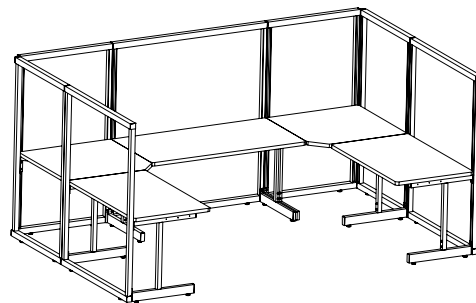

U-Shaped