

## FEATURES

- Programmable Output Voltage to 40V
- Guaranteed 0.5% Reference Voltage Tolerance
- Low (0.2Ω Typ.) Dynamic Output Impedance
- Cathode Current Range (Continuous) – 100 ~ 150 mA
- Equivalent Full Range Temperature Coefficient of 50PPM/°C
- Temperature Compensated For Operation Over Full Rate Operating Temperature Range
- Low Output Noise Voltage
- Fast Turn-on Response
- Available in TO-92, SOT-89 and SOT-23-3L Packages

## APPLICATIONS

- Shunt Regulator
- Precision High-Current Series Regulator
- High-Current Shunt Regulator
- Crowbar Circuit
- PWM Converter With Reference
- Voltage Monitor
- Precision Current Limiter

## DESCRIPTION

The TL431 is a three-terminal adjustable shunt regulator with specified thermal stability over applicable temperature  $V_{REF}$  (2.495V) and 40V with two external resistors. This device has a typical dynamic output impedance of 0.2Ω. Active output circuitry provides a very sharp turn-on characteristic, making this device excellent replacement for Zener diodes in many applications. The TL431 is characterized for operation from -40°C to +125°C.

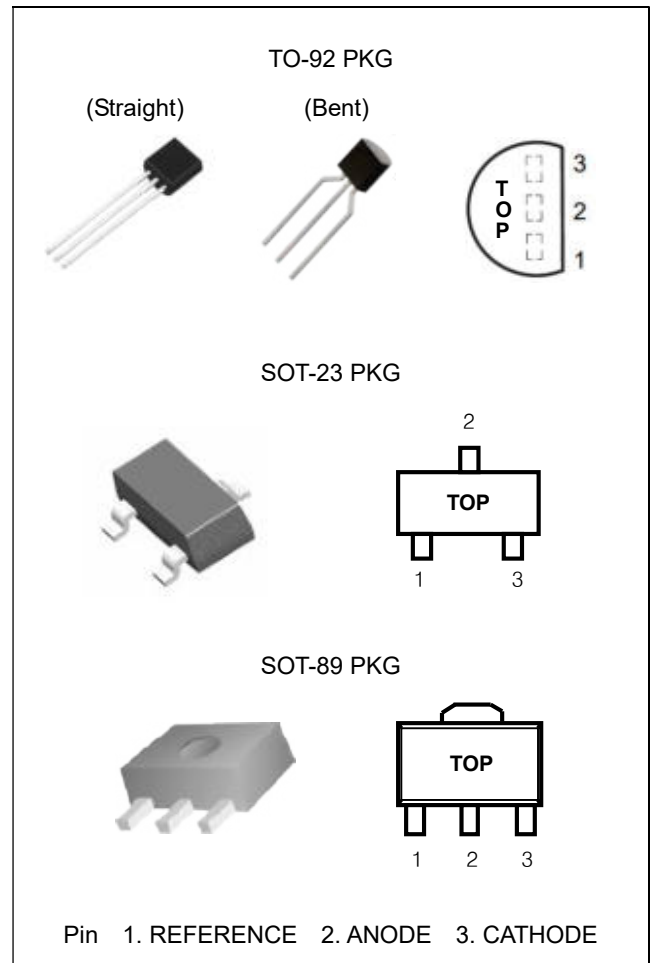

## ORDERING INFORMATION

Device	Package
TL431x	TO-92 (Bulk, Straight)
TL431xTA	TO-92 (Tape, Bent)
TL431xSF	SOT-23-3L
TL431xF	SOT-89-3L

\* Refer to the ordering information for the details.

## ABSOLUTE MAXIMUM RATINGS

(Full operating ambient temperature range applies unless otherwise noted.)

PARAMETER	SYMBOL	MIN.	MAX.	UNIT
Cathode Voltage	$V_{KA}$	-	42	V
Cathode Current Range	$I_{KA}$	-100	150	mA
Reference Input Current Range	$I_{REF}$	-0.05	10	mA
Junction Temperature Range	$T_J$	-40	150	°C
Storage Temperature Range	$T_{STG}$	-65	150	°C

## RECOMMENDED OPERATING CONDITIONS

PARAMETER	SYMBOL	MIN.	MAX.	UNIT
Cathode Voltage	$V_{KA}$	$V_{REF}$	40	V
Cathode Current	$I_{KA}$	0.5	100	mA
Operating Temperature Range	$T_{OPR}$	-40	125	°C

## ORDERING INFORMATION

VREF	Package	Tolerance	Order No.	Marking	Supplied As
2.495V	TO-92	0.5%	TL431C	TL431-C	Bulk (Straight Lead)
			TL431CTA	TL431-C	Tape & Ammo Pack
		1%	TL431A	TL431-A	Bulk (Straight Lead)
			TL431ATA	TL431-A	Tape & Ammo Pack
		2%	TL431	TL431	Bulk (Straight Lead)
			TL431TA	TL431	Tape & Ammo Pack
	SOT-23	0.5%	TL431CSF	431	Tape & Reel
		1%	TL431ASF	431	Tape & Reel
		2%	TL431SF	431	Tape & Reel
	SOT-89	0.5%	TL431CF	431	Tape & Reel
		1%	TL431AF	431	Tape & Reel
		2%	TL431F	431	Tape & Reel

## PIN CONFIGURATION

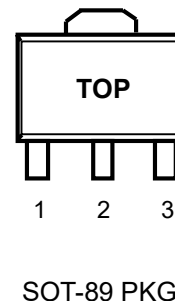
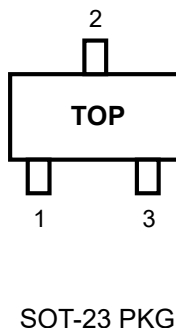
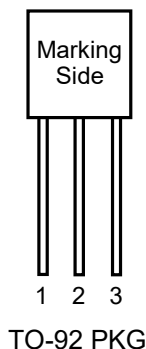

## PIN DESCRIPTION

Pin No.	TO-92 / SOT-23 / SOT-89	
	Pin Name	Pin Description
1	REFERENCE	Reference Voltage
2	ANODE	Ground
3	CATHODE	Input Supply Voltage

## BLOCK DIAGRAM

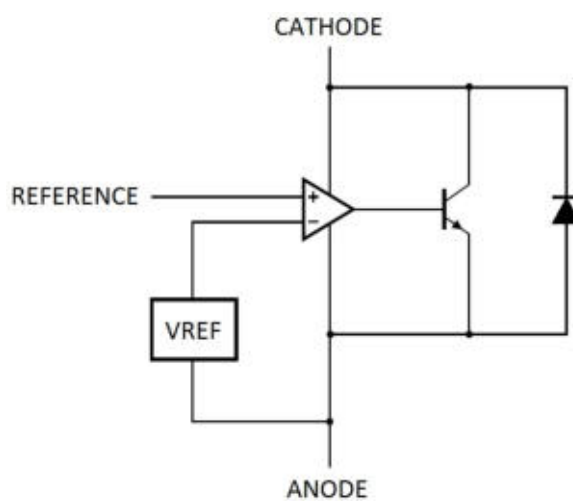

## ELECTRICAL CHARACTERISTICS

(T<sub>A</sub>=25°C, unless otherwise specified)

PARAMETER	SYMBOL	TEST CONDITIONS		MIN.	TYP.	MAX.	UNIT
Reference Input Voltage	V <sub>REF</sub>	V <sub>KA</sub> =V <sub>REF</sub> , I <sub>K</sub> =10mA	TL431C	2.483	2.495	2.507	V
			TL431A	2.470	2.495	2.520	
			TL431	2.440	2.495	2.550	
Deviation of Reference Input Voltage (Note 1)	ΔV <sub>REF</sub> /ΔT	V <sub>KA</sub> = V <sub>REF</sub> , I <sub>K</sub> = 10mA T <sub>A</sub> = Full Range			15	30	mV
Ratio of Change in Reference Input Voltage to the Change in Cathode Voltage	ΔV <sub>REF</sub> /ΔV <sub>KA</sub>	I <sub>K</sub> = 10mA	ΔV <sub>KA</sub> = 10V to V <sub>REF</sub>		-1.4	-2.7	mV/V
			ΔV <sub>KA</sub> = 36V to 10V		-1.0	-2.0	
Reference Input Current	I <sub>REF</sub>	I <sub>KA</sub> = 10mA, R <sub>1</sub> = 10kΩ, R <sub>2</sub> = ∞			1.8	4.0	μA
Deviation of Reference Input Current (Note 1)	ΔI <sub>REF</sub> /ΔT	I <sub>K</sub> = 10mA, R <sub>1</sub> = 10kΩ, R <sub>2</sub> = ∞ T <sub>A</sub> = Full Range			0.4	1.2	μA
Minimum Cathode Current for Regulation	I <sub>K(MIN)</sub>	V <sub>KA</sub> = V <sub>REF</sub>				0.5	mA
Off-State Cathode Current	I <sub>K(OFF)</sub>	V <sub>KA</sub> = 36V, V <sub>REF</sub> = 0			0.17	0.90	μA
Dynamic Impedance (Note 2)	Z <sub>KA</sub>	V <sub>KA</sub> = V <sub>REF</sub> , I <sub>K</sub> = 1mA~100mA f ≤ 1kHz			0.27	0.50	Ω

(Note 1) The deviation parameters ΔV<sub>REF</sub>/ΔT<sub>A</sub> and ΔI<sub>REF</sub>/ΔT<sub>A</sub> are defined as the differences between the maximum and minimum values obtained over the recommended temperature range. The average full-range temperature coefficient of the reference voltage, αV<sub>REF</sub>, is defined as:

$$|\alpha V_{REF}| \text{ (ppm/}^\circ\text{C)} = \frac{\left( \frac{V_{I(dev)}}{V_{REF \text{ at } 25^\circ\text{C}}} \right) \times 10^6}{\Delta T_A}$$

Where:

ΔT<sub>A</sub> is the recommended operating free-air temperature range of the device.

αV<sub>REF</sub> can be positive or negative, depending on whether minimum V<sub>REF</sub> or maximum V<sub>REF</sub>, respectively, occurs at the lower temperature.

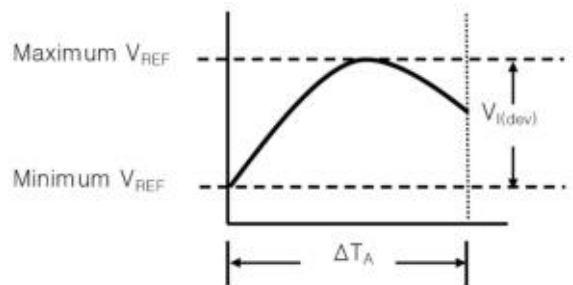

Example : Maximum V<sub>REF</sub>=2496mV at 30°C, minimum V<sub>REF</sub>=2492mV at 0°C, V<sub>REF</sub>=2495mV at 25°C, ΔT<sub>A</sub>=70°C for TL431C.

$$|\alpha V_{REF}| = \frac{\left( \frac{4\text{mV}}{2495\text{mV}} \right) \times 10^6}{70^\circ\text{C}} \approx 23\text{ppm/}^\circ\text{C}$$

Because minimum V<sub>REF</sub> occurs at the lower temperature, the coefficient is positive.

(Note 2) The dynamic impedance is defined as:  $|Z_{KA}| = \frac{\Delta V_{KA}}{\Delta I_{KA}}$

When the device is operating with two external resistors, the total dynamic impedance of the circuit is given by:

$$|Z| = \frac{\Delta V}{\Delta I} \approx |Z_{KA}|(1 + R1/R2)$$

## TEST CIRCUITS

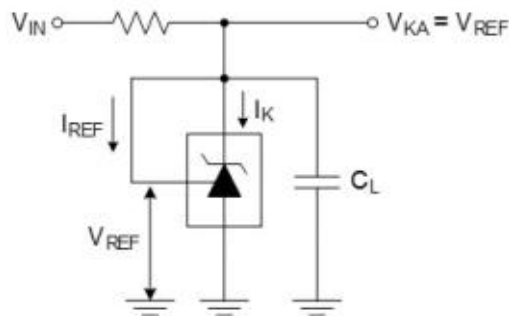

< Fig 1. Test circuit for  $V_{KA} = V_{REF}$  >

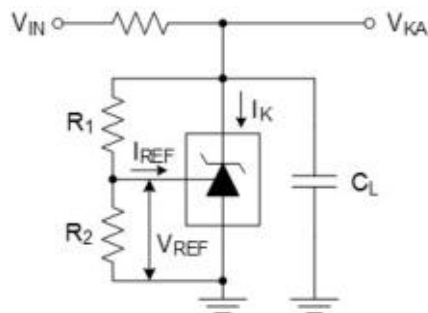
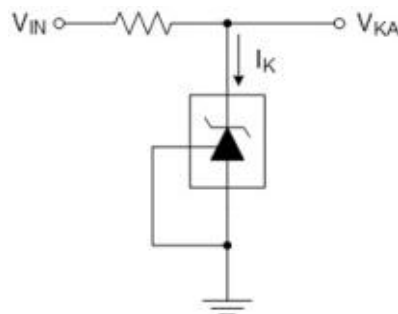

Fig 2. Test circuit for  $V_{KA} \geq V_{REF}$  >



< Fig 3. Test circuit for  $I_{KA(OFF)}$  >

TYPICAL OPERATING CHARACTERISTICS

Reference Voltage vs. Ambient Temperature

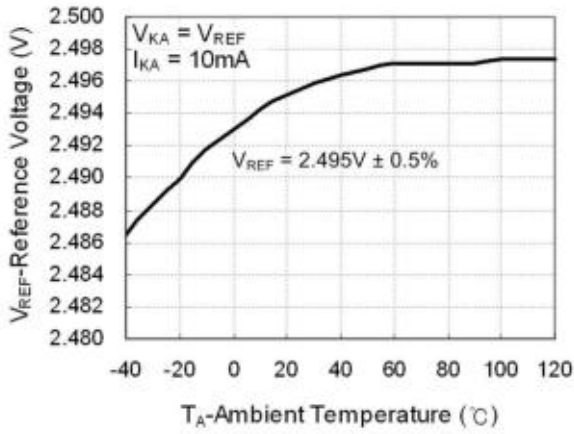

Pulse Response

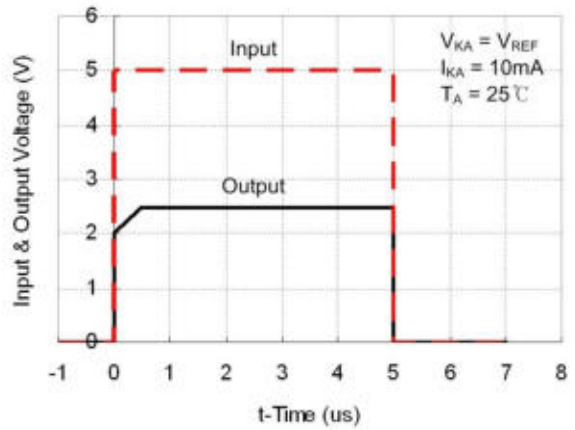

Cathode Current vs. Cathode Voltage

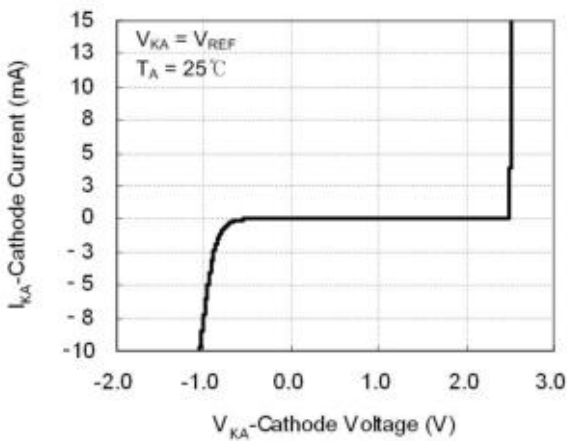

Cathode Current vs. Cathode Voltage

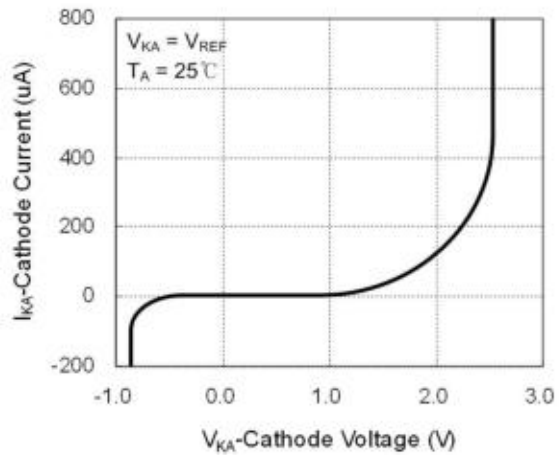

Small Signal Voltage Amplification vs. Frequency

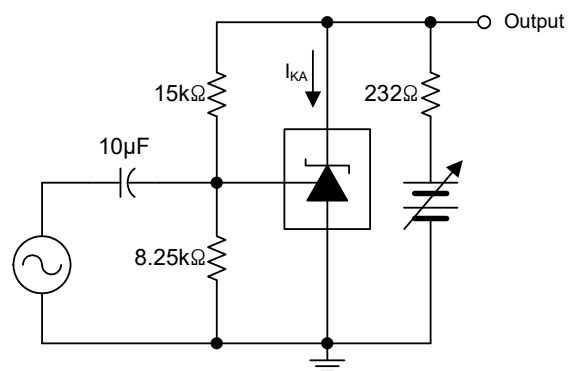
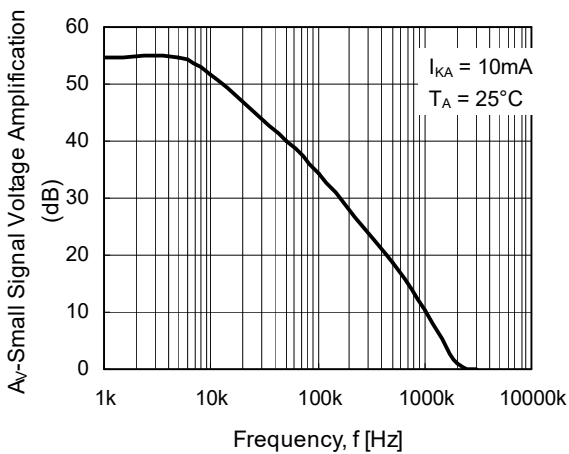

< Fig 4. TEST Circuit for Voltage Amplification >

## APPLICATION INFORMATION

### 1. Shunt Regulator

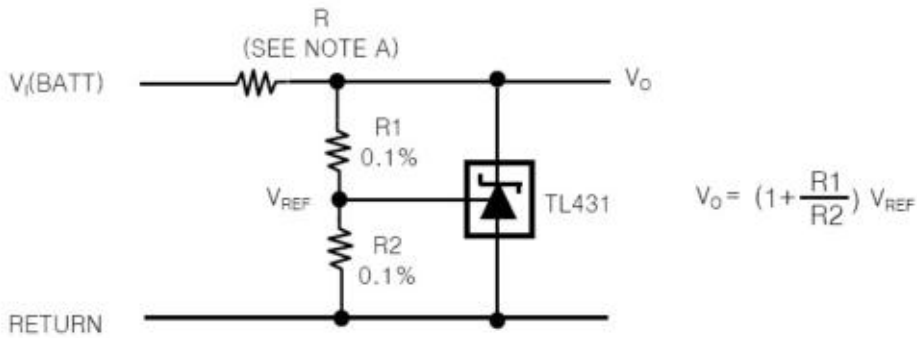

Note: R Should provide cathode current 1mA to the TL431 at minimum  $V_{I(BATT)}$

### 2. Precision High-Current Series Regulator

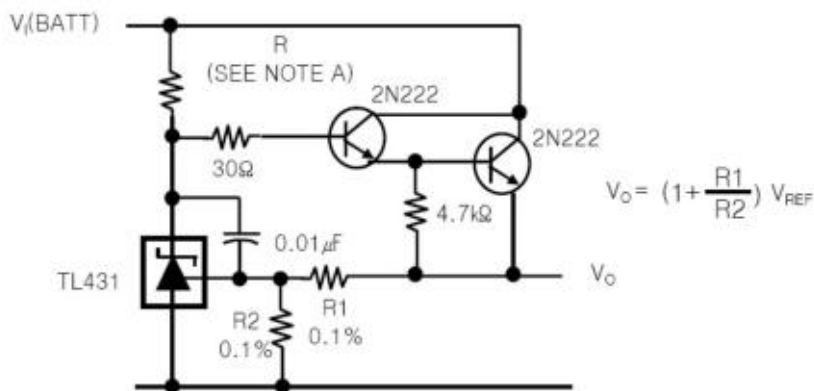

Note: R Should provide cathode current  $\geq 1\text{mA}$  to the TL431 at minimum  $V_{I(BATT)}$

### 3. Output Control of a Three-Terminal Fixed Regulator

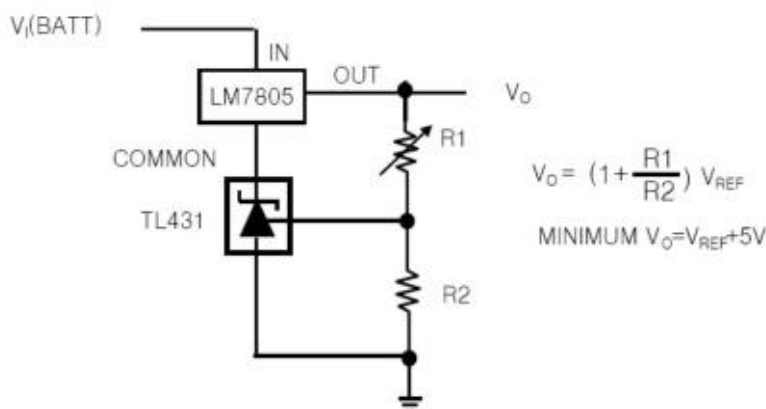

## 4. High-Current Shunt Regulator

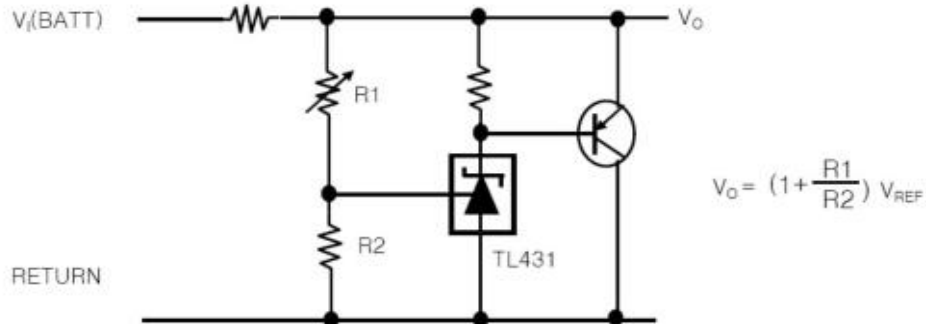

## 5. Precision 5-V 1.5A Regulator

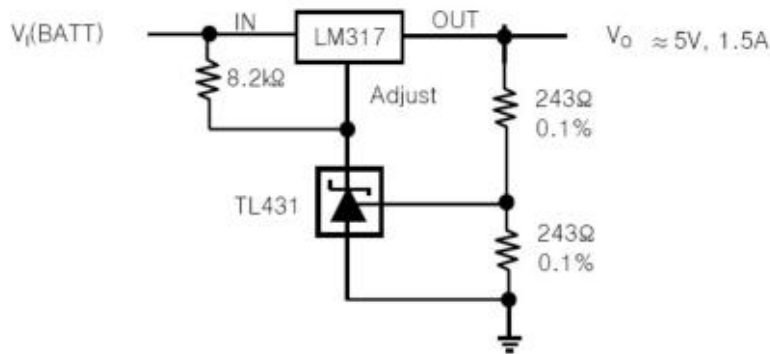

## 6. Efficient 5-V Precision Regulator

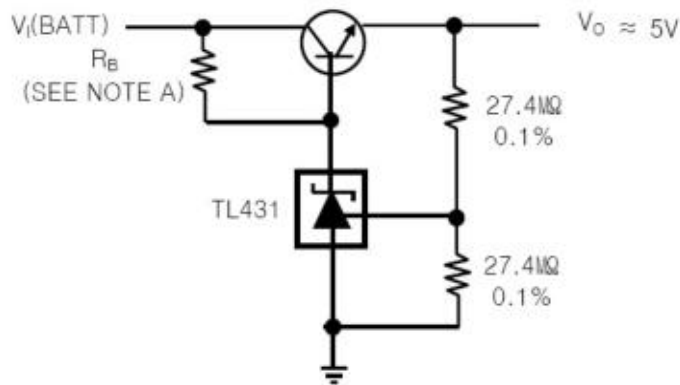

NOTE: R<sub>B</sub> Should provide cathode current ≥ 1mA to the TL431.



## 7. PWM Converter With Reference

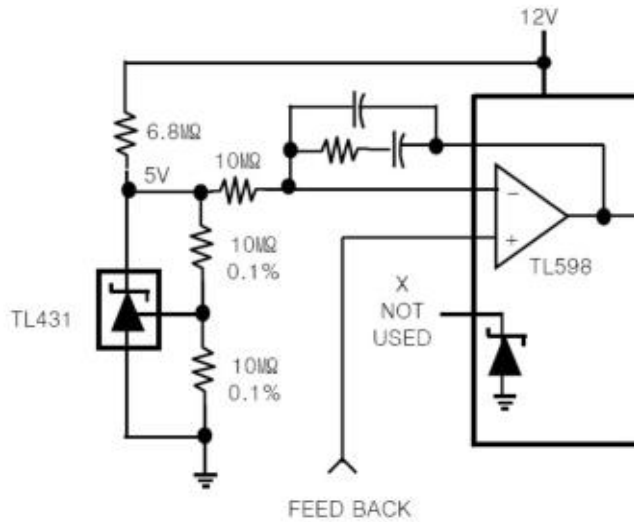

## 8. Voltage Monitor

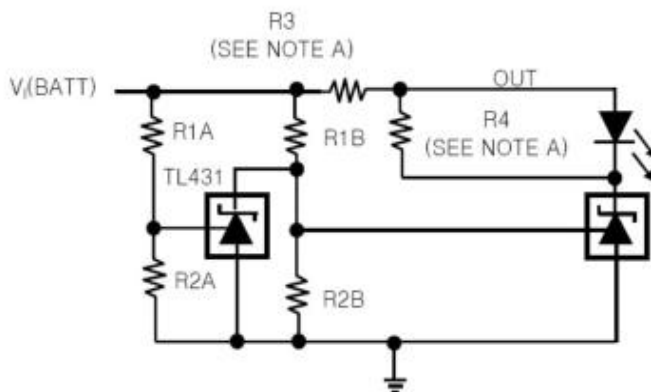

$$\text{LOW LIMIT} = \left(1 + \frac{R1B}{R2B}\right) V_{REF}$$

$$\text{HIGH LIMIT} = \left(1 + \frac{R1A}{R2A}\right) V_{REF}$$

LED ON WHEN  $\text{LOW LIMIT} < V_{(BATT)} < \text{HIGH LIMIT}$

NOTE: R3 and R4 are selected to provide the desired LED intensity and cathode current  $\geq 1\text{mA}$  to the TL431 at the available  $V_{(BATT)}$ .

## 9. Delay Timer

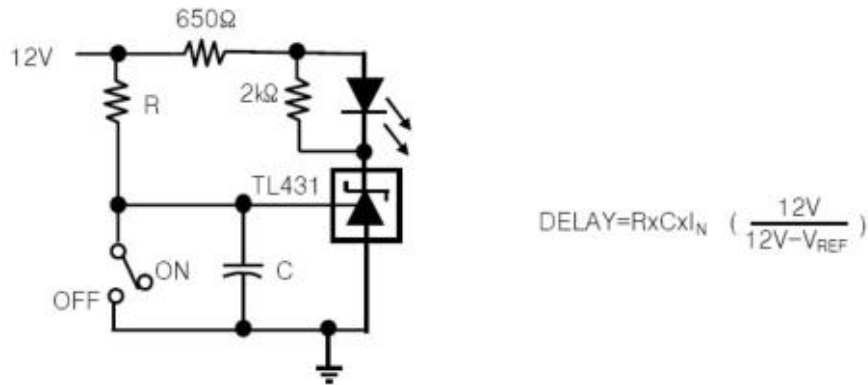

## 10. Precision Current Limiter

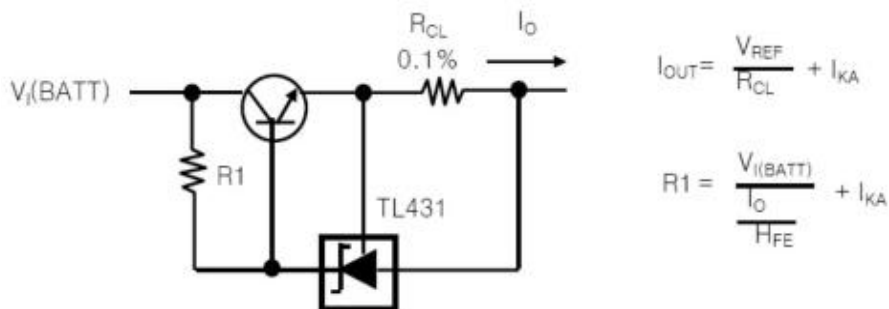

## 11. Precision Constant-Current Sink

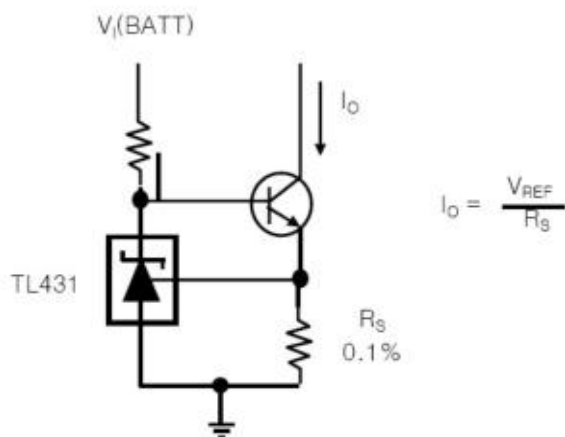

## REVISION NOTICE

The description in this datasheet is subject to change without any notice to describe its electrical characteristics properly.