

FEATURES

- Programmable Output Voltage to 18V
- Low Voltage Operation from 1.24 V
- Sink Current Capability of 1mA to 100mA
- Equivalent Full Range Temperature Coefficient of 50ppm/°C
- Temperature Compensated for Operation over Full Rated Operating Temperature Range
- Low Output Noise Voltage
- Available in TO-92, SOT-89 and SOT-23-3L Packages

APPLICATIONS

- Shunt Regulator
- Voltage Monitoring
- Current Source and Sink Circuits
- Analog & Digital Circuits Requiring Precision References
- Low Out Voltage (3.0V to 3.3V) Switching Power Supply Error Amplifier

DESCRIPTION

The TL432 is a three-terminal Shunt Voltage Reference providing a highly accuracy 1.24V bandgap reference with 0.5% and 1.0% tolerance. The TL432 thermal stability and wide operating current (100mA) makes it suitable for all variety of applications that are looking for a low cost solution with high performance. The TL432 is an ideal voltage reference in an isolated feed circuit for 3.0V to 3.3V switching mode power supplies.

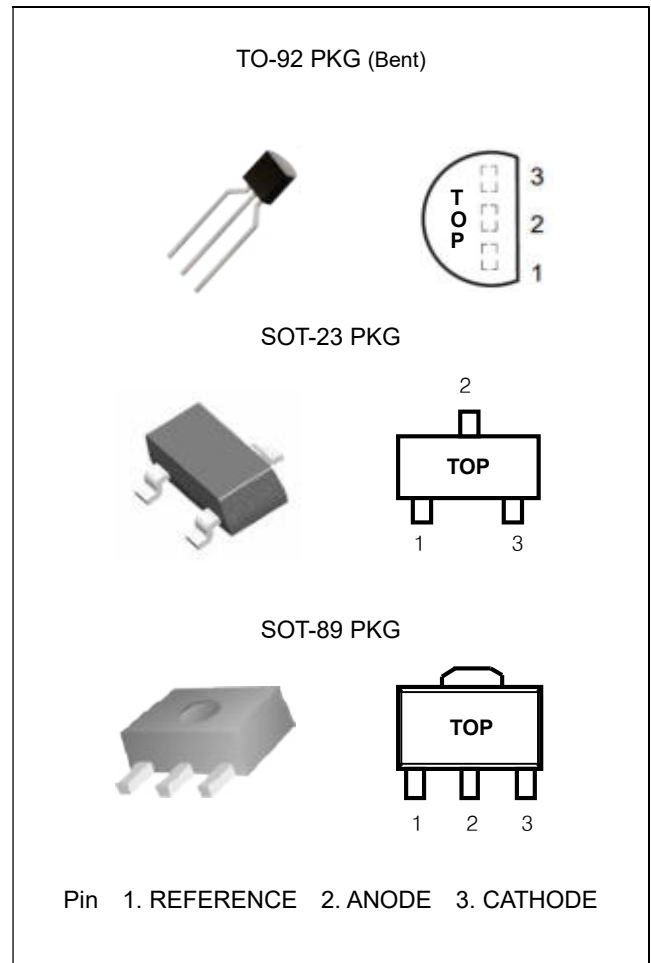

ORDERING INFORMATION

Device	Package
TL432xTA	TO-92 (Tape, Bent)
TL432xSF	SOT-23-3L
TL432xF	SOT-89-3L

* Refer to the ordering information for the details.

ABSOLUTE MAXIMUM RATINGS

(Full operating ambient temperature range applies unless otherwise noted.)

PARAMETER	SYMBOL	MIN.	MAX.	UNIT
Cathode Voltage	V_{KA}	-	20	V
Cathode Current Range	I_{KA}	-	100	mA
Reference Input Current Range	I_{REF}	-	3	mA
Junction Temperature Range	T_J	-40	150	°C
Storage Temperature Range	T_{STG}	-65	150	°C

RECOMMENDED OPERATING CONDITIONS

PARAMETER	SYMBOL	MIN.	MAX.	UNIT
Cathode Voltage	V_{KA}	V_{REF}	18	V
Cathode Current	I_{KA}	0.1	100	mA
Operating Temperature Range	T_{OPR}	-40	125	°C

ORDERING INFORMATION

VREF	Package	Tolerance	Order No.	Marking	Supplied As
1.24V	TO-92	0.5%	TL432CTA	TL432-C	Tape & Ammo Pack
		1%	TL432ATA	TL432-A	Tape & Ammo Pack
	SOT-23	0.5%	TL432CSF	432	Tape & Reel
		1%	TL432ASF	432	Tape & Reel
	SOT-89	0.5%	TL432CF	432	Tape & Reel
		1%	TL432AF	432	Tape & Reel

PIN CONFIGURATION

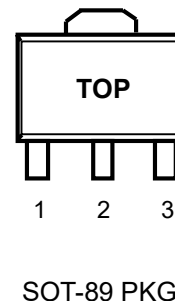
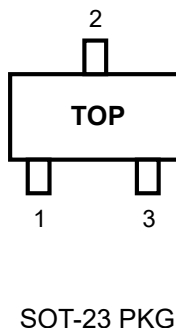
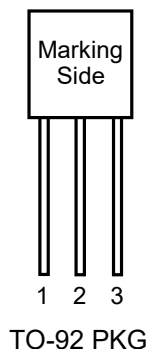

PIN DESCRIPTION

Pin No.	TO-92 / SOT-23 / SOT-89	
	Pin Name	Pin Description
1	REFERENCE	Reference Voltage
2	ANODE	Ground
3	CATHODE	Input Supply Voltage

BLOCK DIAGRAM

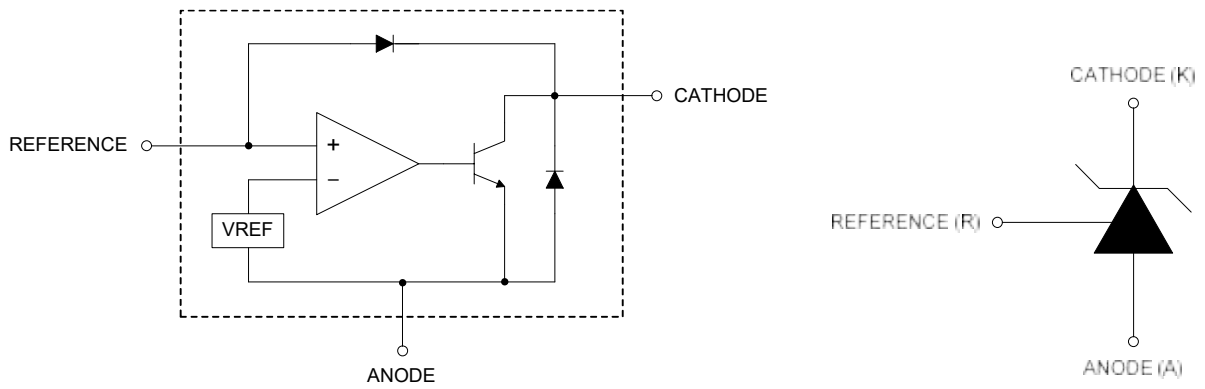

EQUIVALENT SCHEMATIC

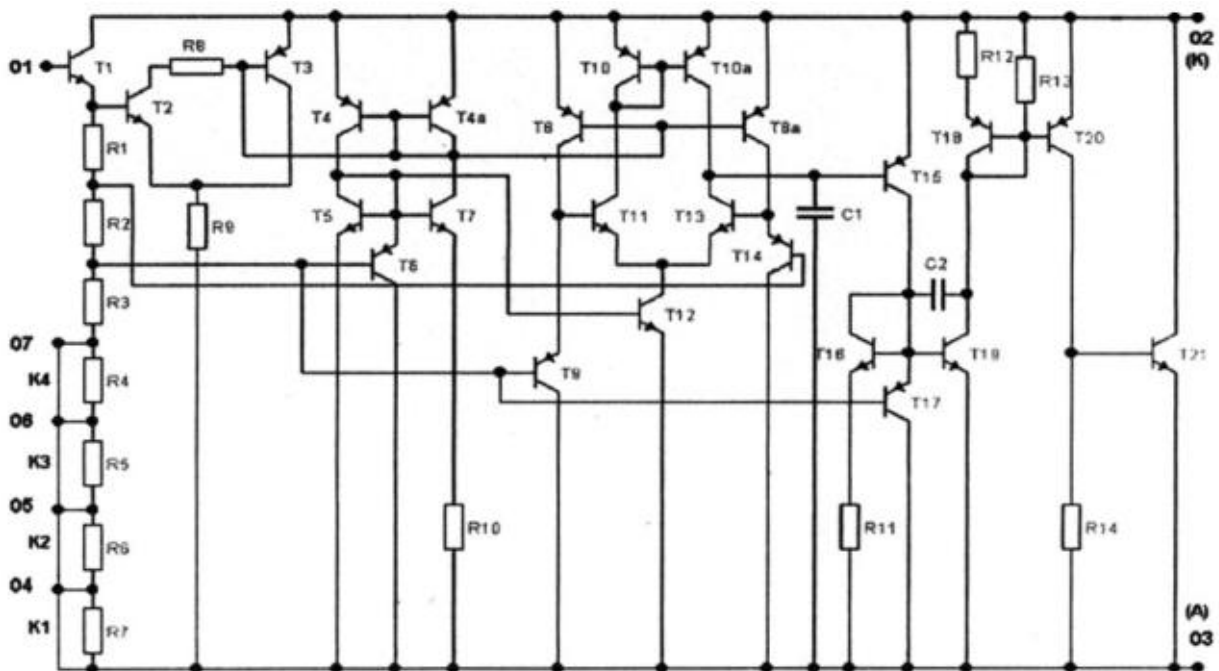

* All component values are nominal.

ELECTRICAL CHARACTERISTICS

(T_A=25°C, unless otherwise specified)

PARAMETER	SYMBOL	TEST CONDITIONS	MIN.	TYP.	MAX.	UNIT	
Reference Input Voltage	V _{REF}	V _{KA} =V _{REF} , I _K =10mA	TL432C	1.234	1.240	1.246	V
			TL432A	1.228	1.240	1.252	
Deviation of Reference Input Voltage (Note 1)	ΔV _{REF} /ΔT	V _{KA} = V _{REF} , I _K = 10mA T _A = Full Range		15	25	mV	
Ratio of Change in Reference Input Voltage to the Change in Cathode Voltage	ΔV _{REF} /ΔV _{KA}	V _{KA} = 1.25V to 14.5V		1.0	2.7	mV/V	
Reference Input Current	I _{REF}	R1=10kΩ, R2=∞		0.25	0.5	μA	
Deviation of Reference Input Current (Note 1)	ΔI _{REF} /ΔT	R1=10kΩ, R2=∞, T _A = Full Range		0.05	0.3	μA	
Minimum Cathode Current for Regulation	I _{K(MIN)}	V _{KA} = V _{REF}		60	80	μA	
Off-State Cathode Current	I _{K(OFF)}	V _{KA} = 16V, V _{REF} = 0		0.04	0.5	μA	
Dynamic Impedance (Note 2)	Z _{KA}	V _{KA} = V _{REF} , I _K = 0.1mA~100mA f ≤ 1kHz		0.2	0.4	Ω	

(Note 1) The deviation parameters ΔV_{REF}/ΔT_A and ΔI_{REF}/ΔT_A are defined as the differences between the maximum and minimum values obtained over the recommended temperature range. The average full-range temperature coefficient of the reference voltage, αV_{REF}, is defined as:

$$|\alpha V_{REF}| \text{ (ppm/}^\circ\text{C)} = \frac{\left(\frac{V_{I(\text{dev})}}{V_{REF} \text{ at } 25^\circ\text{C}} \right) \times 10^6}{\Delta T_A}$$

Where:

ΔT_A is the recommended operating free-air temperature range of the device.

αV_{REF} can be positive or negative, depending on whether minimum V_{REF} or maximum V_{REF}, respectively, occurs at the lower temperature.

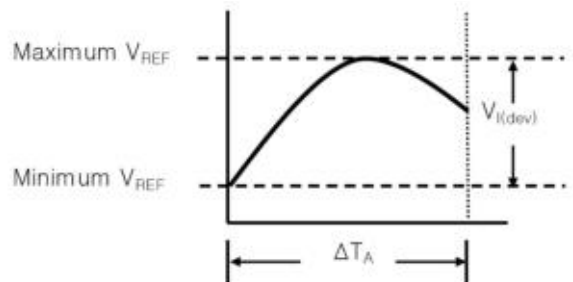

(Note 2) The dynamic impedance is defined as: $|Z_{KA}| = \frac{\Delta V_{KA}}{\Delta I_{KA}}$

When the device is operating with two external resistors, the total dynamic impedance of the circuit is given by:

$$|Z'| = \frac{\Delta V}{\Delta I} \approx |Z_{KA}| (1 + R1/R2)$$

TEST CIRCUITS

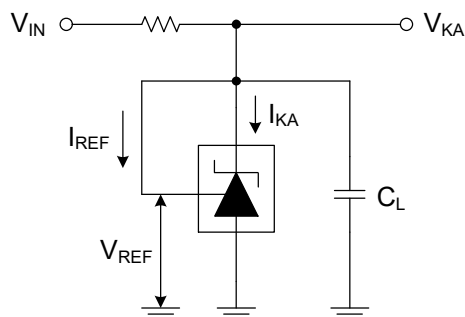

< Fig 1. Test circuit for $V_{KA} = V_{REF}$ >

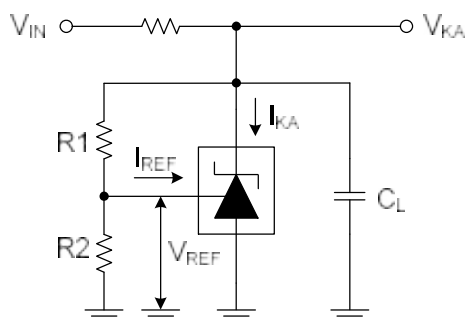
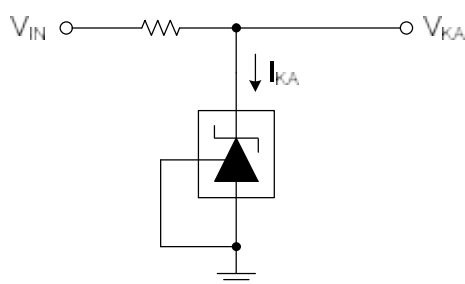

Fig 2. Test circuit for $V_{KA} \geq V_{REF}$ >



< Fig 3. Test circuit for $I_{KA(OFF)}$ >

TYPICAL OPERATING CHARACTERISTICS

Reference Voltage vs. Junction Temperature

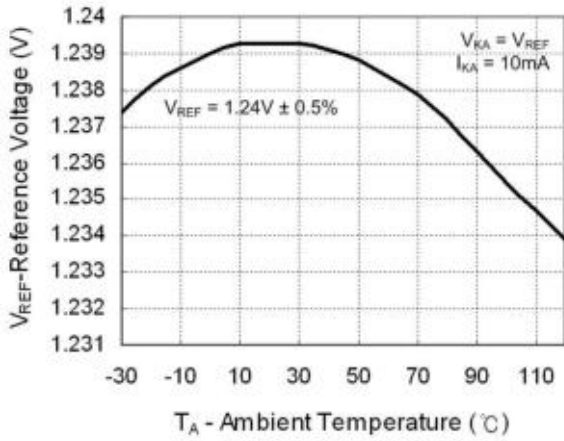

Stability Boundary Conditions

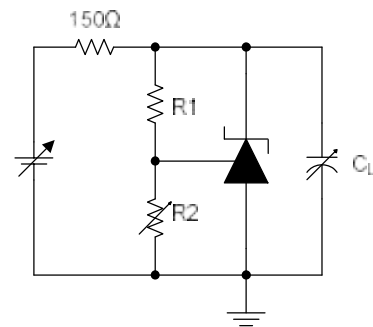
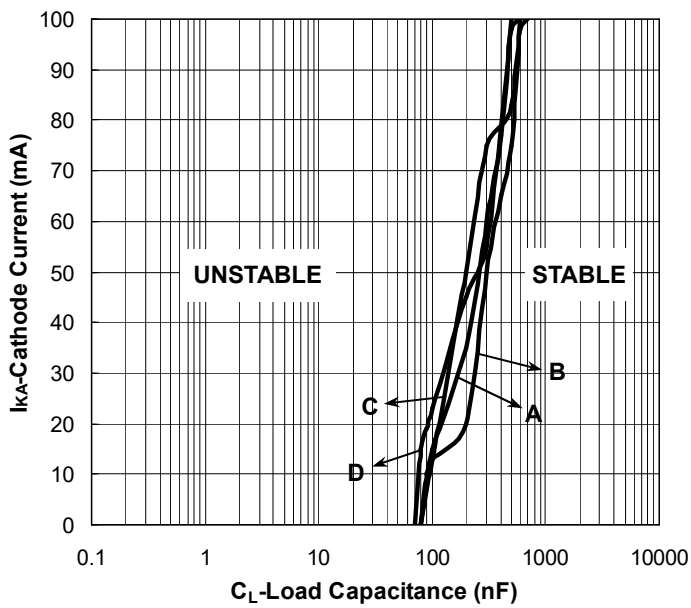

< Fig 4. Test Circuit >

- A $V_{KA}=V_{REF}$ $R1= 0\Omega$, $R2 = \infty$
- B $V_{KA}=5.0V$, $R1=10k\Omega$, $R2 = 3.3k\Omega$
- C $V_{KA}=10.0V$ $R1=10k\Omega$, $R2 = 1.42k\Omega$
- D $V_{KA}=15.0V$ $R1=10k\Omega$, $R2 = 900\Omega$

REVISION NOTICE

The description in this datasheet is subject to change without any notice to describe its electrical characteristics properly.