

FEATURES

- Complete PWM Power Control Circuitry
- Uncommitted Outputs for 200mA Sink or Source Current
- Output Control Selects Single-Ended or Push-Pull Operation
- Internal Circuitry Prohibits Double Pulse at Either Output
- Variable Dead-Time Provides Control over Total Range
- Internal Regulator Provides a Stable 5V Reference Supply
- Circuit Architecture Allows Easy Synchronization
- Available in SOP-16 and DIP-16 Packages

DESCRIPTION

The TL494 incorporates on a single monolithic chip all the functions required in the construction of a pulse width modulation control circuit. Designed primarily for power supply control, this device offers the systems engineer the flexibility to tailor the power supply control circuitry to one's application.

The TL494 contains an error amplifier, an on-chip adjustable oscillator, a dead-time control comparator, pulse-steering control flip-flop, a 5 volt precision regulator, and output-control circuits. The error amplifier exhibits a common-mode voltage range from -0.3 volts to $V_{CC}-2$ volts. The dead-time control comparator has a fixed offset that provides approximately 5% dead time when externally altered. The on-chip oscillator may be bypassed by terminating RT (pin 6) to the reference output and providing a sawtooth input to CT (pin 5), or it may be used to drive the common circuits in synchronous multiple-rail power supplies. The uncommitted output transistors provide either common-emitter or emitter-follower output capability. Each Device provides for push-pull or single-ended output operation, which may be selected through the output-control function. The architecture of these devices prohibits the possibility of either output being pulsed twice during push-pull operation.

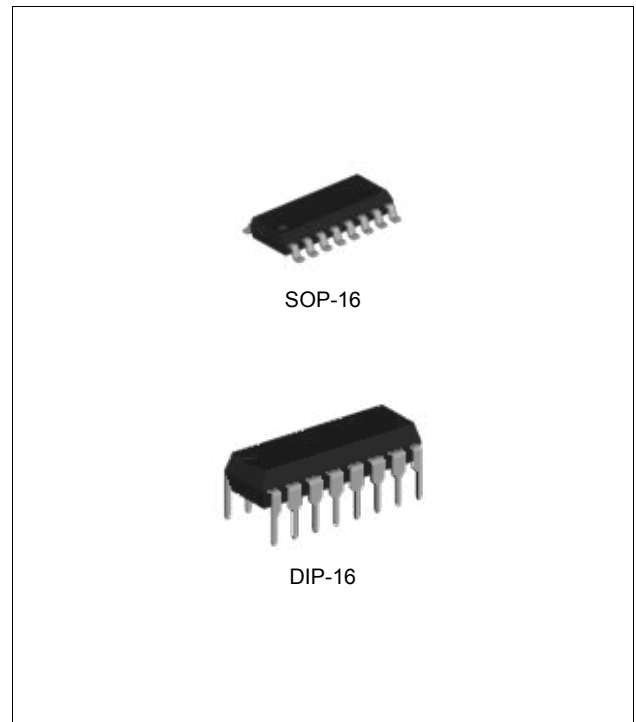

ORDERING INFORMATION

Device	Package
TL494D	SOP-16
TL494GD	SOP-16
TL494N	DIP-16

ABSOLUTE MAXIMUM RATINGS ^(Note 1)

CHARACTERISTIC	SYMBOL	MIN	MAX	UNIT
Supply Voltage	V_{CC}	-0.3	41	V
Amplifier Input Voltage	V_I	-0.3	$V_{CC} + 0.3$	V
Collector Output Voltage	V_O	-	41	V
Collector Output Current	I_O	-	250	mA
Junction Temperature Range	T_J	-40	125	°C
Storage Temperature Range	T_{STG}	-65	150	°C

Note 1. Exceeding the absolute maximum ratings may damage the device.

RECOMMENDED OPERATING RATINGS ^(Note 2)

CHARACTERISTIC	SYMBOL	MIN	MAX	UNIT
Supply Voltage	V_{CC}	7.0	40	V
Amplifier Input Voltage	V_I	-0.3	$V_{CC} - 2.0$	V
Collector Output Voltage	V_O	-	40	V
Collector Output Current (each transistor)		-	200	mA
Current into Feedback Terminal		-	0.3	mA
Oscillation Frequency	f_{OSC}	1.0	200	kHz
Timing Capacitor	C_T	0.47	10,000	nF
Timing Resistor	R_T	1.8	500	k Ω
Operating Free-Air Temperature Range	T_A	-40	85	°C

Note 2. The device is not guaranteed to function outside its operating ratings.

ORDERING INFORMATION

Package	Order No.	Description	Supplied As	Status
SOP-16	TL494D	PWM Control Circuits	Tape & Reel	Contact Us
SOP-16	TL494GD	PWM Control Circuits	Tape & Reel	Active
DIP-16	TL494N	PWM Control Circuits	Tube	Active

PIN CONFIGURATION

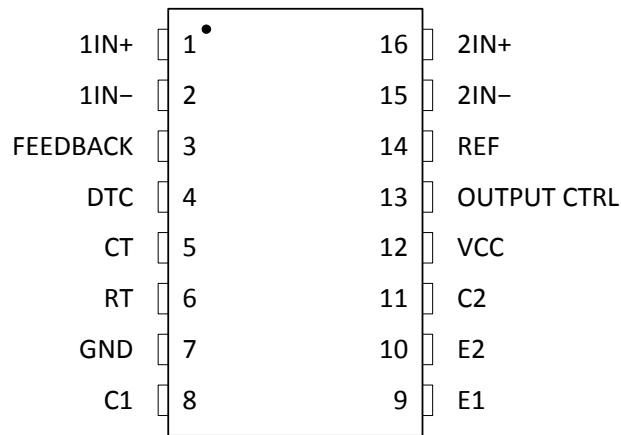

SOP-16 / DIP-16

PIN DESCRIPTION

Pin No.		Pin Name	Pin Function
SOP-16	DIP-16		
1	1	1IN+	Noninverting Input to Error Amplifier 1
2	2	1IN-	Inverting Input to Error Amplifier 1
3	3	FEEDBACK	Input for Feedback
4	4	DTC	Dead-Time Control Comparator Input
5	5	CT	Capacitor Terminal Used to Set Oscillator Frequency
6	6	RT	Resistor Terminal Used to Set Oscillator Frequency
7	7	GND	Ground
8	8	C1	Collector Terminal of BJT Output 1
9	9	E1	Emitter Terminal of BJT Output 1
10	10	E2	Emitter Terminal of BJT Output 2
11	11	C2	Collector Terminal of BJT Output 2
12	12	VCC	Power Supply
13	13	OUTPUT CTRL	Selects Single-ended/ Parallel Output or Push-pull Operation
14	14	REF	5V Reference Regulator Output
15	15	2IN-	Inverting Input to Error Amplifier 2
16	16	2IN+	Noninverting Input to Error Amplifier 2

ELECTRICAL CHARACTERISTICS

$V_{CC} = 15V$, for typical values $T_A = 25^\circ C$, unless otherwise noted.

PARAMETER	SYMBOL	TEST CONDITIONS	MIN	TYP	MAX	UNIT	
REFERENCE SECTION (f = 10 kHz)							
Output Voltage	V_{REF}	$I_O = 1.0 \text{ mA}$	4.75	5.0	5.25	V	
Line Regulation	LNR	$V_{CC} = 7.0 \text{ V to } 40 \text{ V}$	-	2.0	25	mV	
Load Regulation	LDR	$I_O = 1.0 \text{ mA to } 10 \text{ mA}$	-	1.0	15	mV	
Short-Circuit Output Current ^(Note 3)	I_{SC}	$V_{REF} = 0 \text{ V}$	-	35	-	mA	
OSCILLATOR SECTION ($C_T = 0.01 \mu F$, $R_T = 12 \text{ k}\Omega$, see Figure 1)							
Frequency	f_{OSC}		-	10	-	kHz	
Frequency Change with Temperature ^(Note 4)	$\Delta f_{OSC,T}$	$\Delta T_A = \text{MIN to MAX}$	-	2.0	-	%	
ERROR AMPLIFIER SECTION (see Figure 2)							
Input Offset Voltage	V_{IO}	$V_{O(FEEDBACK)} = 2.5 \text{ V}$	-	2.0	10	mV	
Input Offset Current	I_{IO}	$V_{O(FEEDBACK)} = 2.5 \text{ V}$	-	25	250	nA	
Input Bias Current	$I_{B,FB}$	$V_{O(FEEDBACK)} = 2.5 \text{ V}$	-	0.2	1.0	μA	
Common-Mode Input Voltage Range	V_{CM}	$V_{CC} = 7.0 \text{ V to } 40 \text{ V}$	-0.3	-	$V_{CC}-2$	V	
Open-Loop Voltage Amplification	A_{VOL}	$\Delta V_O = 3.0 \text{ V}$, $V_O = 0.5 \text{ V to } 3.5 \text{ V}$, $R_L = 2 \text{ k}\Omega$	70	95	-	dB	
Unity Gain Bandwidth	G_{BW}	$V_O = 0.5 \text{ V to } 3.5 \text{ V}$, $R_L = 2 \text{ k}\Omega$	-	650	-	kHz	
Common-Mode Rejection Ratio	CMRR	$V_O = 40V$, $T_A = 25^\circ C$	65	80	-	dB	
Output Sink Current	I_{OSINK}	$V_{ID} = -15 \text{ mV to } -5.0 \text{ V}$, $V_{FEEDBACK} = 0.7 \text{ V}$	0.3	0.7	-	mA	
Output Source Current	I_{OSRC}	$V_{ID} = 15 \text{ mV to } 5.0 \text{ V}$, $V_{FEEDBACK} = 3.5 \text{ V}$	-2.0	-	-	mA	
OUTPUT SECTION							
Collector Off-State Current	$I_{OFF,C}$	$V_{CC} = 40 \text{ V}$, $V_{CE} = 40 \text{ V}$	-	2.0	100	μA	
Emitter Off-State Current	$I_{OFF,E}$	$V_{CC} = V_C = 40 \text{ V}$, $V_E = 0 \text{ V}$	-	-	-100	μA	
Collector-Emitter Saturation Voltage	Common-Emitter	$V_{CE,SAT}$	$V_E = 0 \text{ V}$, $I_C = 200 \text{ mA}$	-	1.1	1.3	V
	Emitter-Follower	$V_{CE,SAT}$	$V_C = 15 \text{ V}$, $I_E = -200 \text{ mA}$	-	1.5	2.5	V
Output Control Input Current	I_{OC}	$V_I = V_{REF}$	-	-	3.5	mA	

ELECTRICAL CHARACTERISTICS (Continued)

$V_{CC} = 15V$, $T_A = 25^\circ C$ for typical values, unless otherwise noted.

PARAMETER	SYMBOL	TEST CONDITIONS	MIN	TYP	MAX	UNIT	
DEAD-TIME CONTROL SECTION (see Figure 1)							
Input Bias Current (DTC)	$I_{B,DTC}$	$V_I = 0 V$ to $5.25 V$	-	-2.0	-10	μA	
Maximum Duty Cycle, Each Output	D_{MAX}	$V_{I(DTC)} = 0 V$, $V_{(OUTPUT CTRL)} = V_{REF}$	-	45	-	%	
Input Threshold Voltage (DTC)	V_{ITH}	Zero Duty Cycle	-	3.0	3.3	V	
		Maximum Duty Cycle	0	-	-	V	
PWM COMPARATOR SECTION (see Figure 1)							
Input Threshold Voltage (FEEDBACK)	V_{IT}	Zero Duty Cycle	-	4.0	4.5	V	
Input Sink Current (FEEDBACK)	I_{SINK}	$V_{FEEDBACK} = 0.7 V$	0.3	0.7	-	mA	
TOTAL DEVICE							
Standby Supply Current	I_{STBY}	$V_{RT} = V_{REF}$, All other inputs and outputs open	$V_{CC} = 15 V$	-	6.0	10	mA
			$V_{CC} = 40 V$	-	9.0	15	mA
Average Supply Current	I_{CC}	$V_{I(DTC)} = 2.0 V$	-	7.5	-	mA	
SWITCHING CHARACTERISTICS (see Figure 3 and 4)							
Output Voltage Rise Time	t_r	Common-Emitter Configuration	-	100	200	ns	
		Emitter-Follower Configuration	-	100	200	ns	
Output Voltage Fall Time	t_f	Common-Emitter Configuration	-	25	100	ns	
		Emitter-Follower Configuration	-	40	100	ns	

Note 3. Duration of the short-circuit should not exceed one second.

Note 4. The temperature coefficient of timing capacitor and timing resistor are not taken into account.

PARAMETER MEASUREMENT INFORMATION

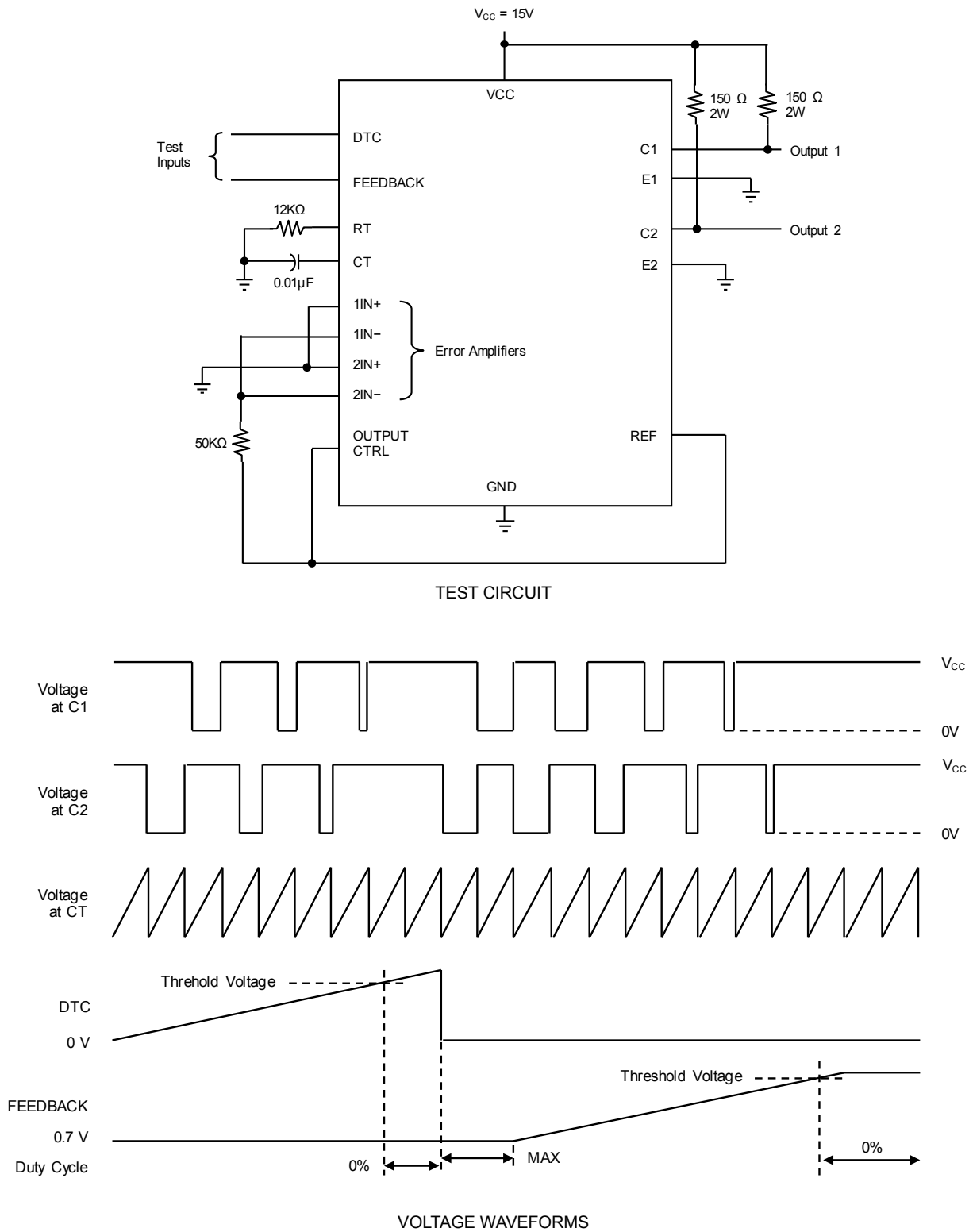

Fig 1. Operational Test Circuit and Waveforms

PARAMETER MEASUREMENT INFORMATION (continued)

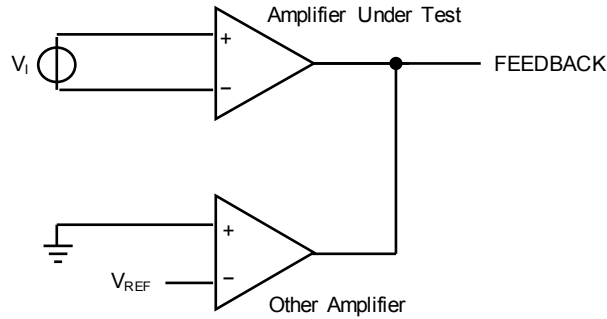

Fig 2. Amplifier Characteristics

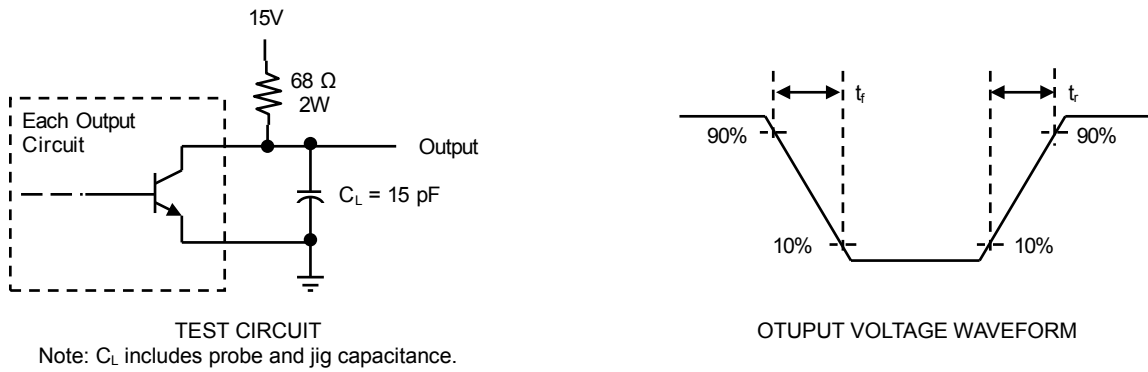

Fig. 3. Common-Emitter Configuration

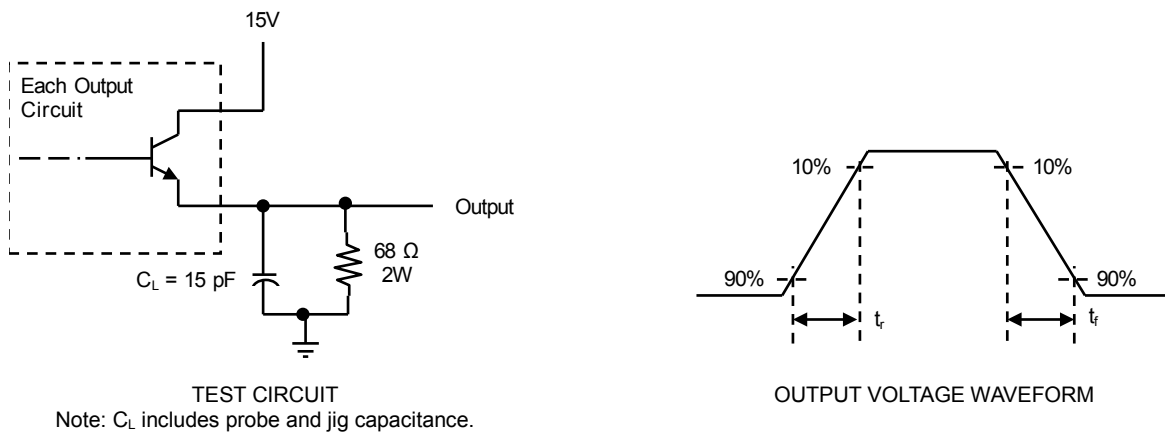
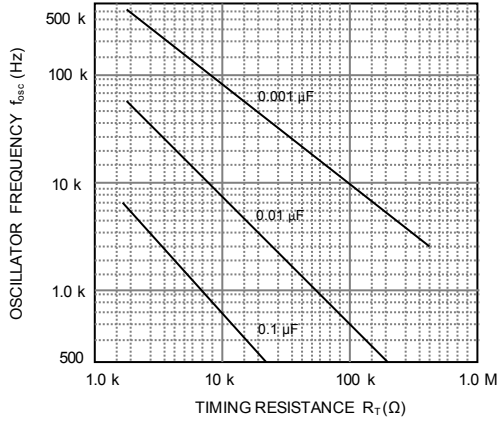
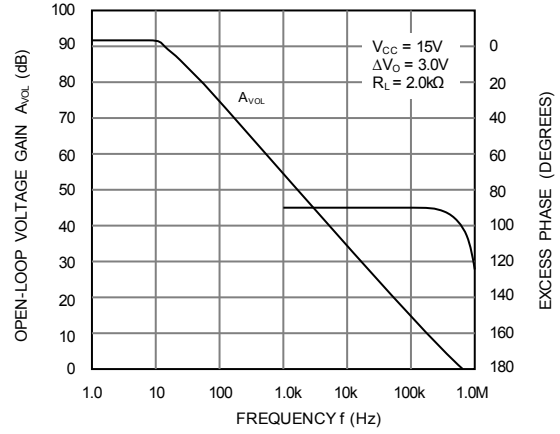

Fig. 4. Emitter-Follower Configuration

TYPICAL CHARACTERISTICS



Oscillator Frequency vs. Timing Resistance



Open Loop Voltage Gain and Phase vs. Frequency

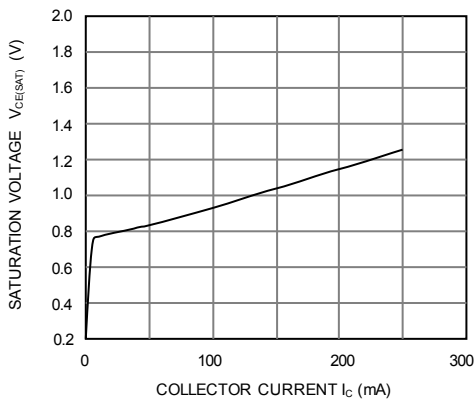

Common-Emitter Configuration Output Saturation Voltage vs. Collector Current

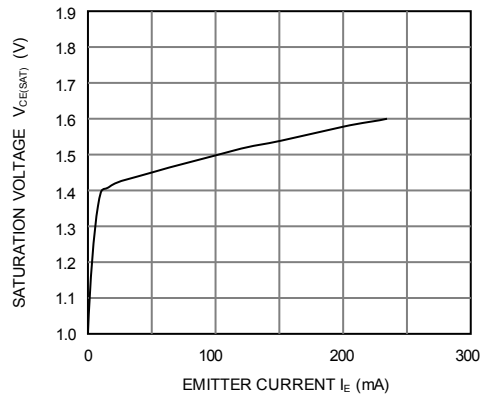

Emitter-Follower Configuration Output Saturation Voltage vs. Emitter Current

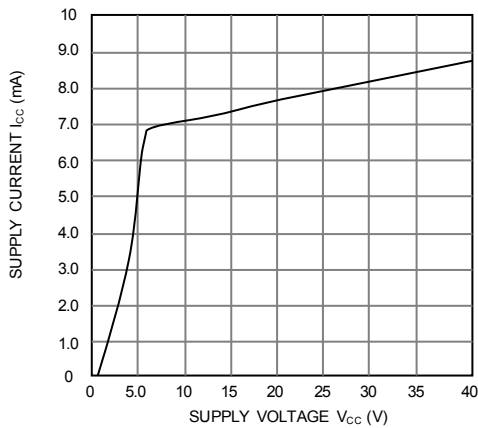

Standby Supply Current vs. Supply Voltage

REVISION NOTICE

The description in this datasheet is subject to change without any notice to describe its electrical characteristics properly.